

Simulink®

Modeling Guidelines for High-Integrity Systems



MATLAB® & SIMULINK®

R2018a



How to Contact MathWorks



Latest news: www.mathworks.com
Sales and services: www.mathworks.com/sales_and_services
User community: www.mathworks.com/matlabcentral
Technical support: www.mathworks.com/support/contact_us



Phone: 508-647-7000



The MathWorks, Inc.
3 Apple Hill Drive
Natick, MA 01760-2098

Modeling Guidelines for High-Integrity Systems

© COPYRIGHT 2009–2018 by The MathWorks, Inc.

The software described in this document is furnished under a license agreement. The software may be used or copied only under the terms of the license agreement. No part of this manual may be photocopied or reproduced in any form without prior written consent from The MathWorks, Inc.

FEDERAL ACQUISITION: This provision applies to all acquisitions of the Program and Documentation by, for, or through the federal government of the United States. By accepting delivery of the Program or Documentation, the government hereby agrees that this software or documentation qualifies as commercial computer software or commercial computer software documentation as such terms are used or defined in FAR 12.212, DFARS Part 227.72, and DFARS 252.227-7014. Accordingly, the terms and conditions of this Agreement and only those rights specified in this Agreement, shall pertain to and govern the use, modification, reproduction, release, performance, display, and disclosure of the Program and Documentation by the federal government (or other entity acquiring for or through the federal government) and shall supersede any conflicting contractual terms or conditions. If this License fails to meet the government's needs or is inconsistent in any respect with federal procurement law, the government agrees to return the Program and Documentation, unused, to The MathWorks, Inc.

Trademarks

MATLAB and Simulink are registered trademarks of The MathWorks, Inc. See www.mathworks.com/trademarks for a list of additional trademarks. Other product or brand names may be trademarks or registered trademarks of their respective holders.

Patents

MathWorks products are protected by one or more U.S. patents. Please see www.mathworks.com/patents for more information.

Revision History

September 2009	Online only	New for Version 1.0 (Release 2009b)
April 2010	Online only	Revised for Version 1.1 (Release 2010a)
September 2010	Online only	Revised for Version 1.2 (Release 2010b)
April 2011	Online only	Revised for Version 1.3 (Release 2011a)
September 2011	Online only	Revised for Version 1.4 (Release 2011b)
March 2012	Online only	Revised for Version 1.5 (Release 2012a)
September 2012	Online only	Revised for Version 1.6 (Release 2012b)
March 2013	Online only	Revised for Version 1.7 (Release 2013a)
September 2013	Online only	Revised for Version 1.8 (Release 2013b)
March 2014	Online only	Revised for Version 1.9 (Release 2014a)
October 2014	Online only	Revised for Version 1.10 (Release 2014b)
March 2015	Online only	Revised for Version 1.11 (Release 2015a)
September 2015	Online only	Revised for Version 1.12 (Release 2015b)
March 2016	Online only	Revised for Version 1.13 (Release 2016a)
September 2016	Online only	Revised for Version 1.14 (Release 2016b)
March 2017	Online only	Revised for Version 1.15 (Release 2017a)
September 2017	Online only	Revised for Version 1.16 (Release 2017b)
March 2018	Online only	Revised for Version 1.17 (Release 2018a)

	Introduction
1	
	Motivation 1-2
	Guideline Template 1-3
	Model Advisor Checks for High-Integrity Modeling
	Guidelines 1-4

	Simulink Block Considerations
2	
	Math Operations 2-2
	hisl_0001: Usage of Abs block 2-2
	hisl_0002: Usage of Math Function blocks (rem and reciprocal) 2-4
	hisl_0003: Usage of Square Root blocks 2-6
	hisl_0028: Usage of Reciprocal Square Root blocks 2-7
	hisl_0004: Usage of Math Function blocks (natural logarithm and base 10 logarithm) 2-9
	hisl_0005: Usage of Product blocks 2-13
	hisl_0029: Usage of Assignment blocks 2-15
	hisl_0066: Usage of Gain blocks 2-19
	Ports & Subsystems 2-21
	hisl_0006: Usage of While Iterator blocks 2-21
	hisl_0007: Usage of While Iterator subsystems 2-23
	hisl_0008: Usage of For Iterator Blocks 2-24
	hisl_0009: Usage of For Iterator Subsystem blocks 2-26
	hisl_0010: Usage of If blocks and If Action Subsystem blocks 2-27

hisl_0011: Usage of Switch Case blocks and Action Subsystem blocks	2-30
hisl_0012: Usage of conditionally executed subsystems	2-32
hisl_0024: Inport interface definition	2-33
hisl_0025: Design min/max specification of input interfaces	2-35
hisl_0026: Design min/max specification of output interfaces	2-37
Signal Routing	2-39
hisl_0013: Usage of data store blocks	2-39
hisl_0015: Usage of Merge blocks	2-43
hisl_0021: Consistent vector indexing method	2-45
hisl_0022: Data type selection for index signals	2-46
hisl_0023: Verification of model and subsystem variants	2-47
hisl_0034: Usage of Signal Routing blocks	2-48
Logic and Bit Operations	2-50
hisl_0016: Usage of blocks that compute relational operators	2-50
hisl_0017: Usage of blocks that compute relational operators (2)	2-52
hisl_0018: Usage of Logical Operator block	2-54
hisl_0019: Usage of Bitwise Operator block	2-55
Lookup Table Blocks	2-57
hisl_0033: Usage of Lookup Table blocks	2-57

Stateflow Chart Considerations

3

Chart Properties	3-2
hisf_0001: Mealy and Moore semantics	3-2
hisf_0002: User-specified state/transition execution order	3-4
hisf_0009: Strong data typing (Simulink and Stateflow boundary)	3-6
hisf_0011: Stateflow debugging settings	3-8
Chart Architecture	3-12
hisf_0003: Usage of bitwise operations	3-12
hisf_0004: Usage of recursive behavior	3-13

hisf_0007: Usage of junction conditions (maintaining mutual exclusion)	3-15
hisf_0013: Usage of transition paths (crossing parallel state boundaries)	3-16
hisf_0014: Usage of transition paths (passing through states)	3-19
hisf_0015: Strong data typing (casting variables and parameters in expressions)	3-20
hisf_0016: Stateflow port names	3-22
hisf_0017: Stateflow data object scoping	3-23

MATLAB Function and MATLAB Code Considerations

4

MATLAB Functions	4-2
himl_0001: Usage of standardized MATLAB function headers	4-2
himl_0002: Strong data typing at MATLAB function boundaries	4-3
himl_0003: Limitation of MATLAB function complexity	4-6
himl_0005: Usage of global variables in MATLAB functions	4-8
MATLAB Code	4-12
himl_0004: MATLAB Code Analyzer recommendations for code generation	4-12
himl_0006: MATLAB code if / elseif / else patterns	4-16
himl_0007: MATLAB code switch / case / otherwise patterns	4-18
himl_0008: MATLAB code relational operator data types	4-20
himl_0009: MATLAB code with equal / not equal relational operators	4-21
himl_0010: MATLAB code with logical operators and functions	4-22

Solver	5-2
hisl_0040: Configuration Parameters > Solver > Simulation time	5-2
hisl_0041: Configuration Parameters > Solver > Solver options	5-4
hisl_0042: Configuration Parameters > Solver > Tasking and sample time options	5-5
 Math and Data Types	 5-7
hisl_0048: Configuration Parameters > Math and Data Types > Application lifespan (days)	5-7
 Diagnostics	 5-9
hisl_0036: Configuration Parameters > Diagnostics > Saving	5-10
hisl_0043: Configuration Parameters > Diagnostics > Solver	5-11
hisl_0044: Configuration Parameters > Diagnostics > Sample Time	5-14
hisl_0301: Configuration Parameters > Diagnostics > Compatibility	5-17
hisl_0302: Configuration Parameters > Diagnostics > Data Validity > Parameters	5-19
hisl_0303: Configuration Parameters > Diagnostics > Merge block	5-20
hisl_0304: Configuration Parameters > Diagnostics > Model initialization	5-22
hisl_0305: Configuration Parameters > Diagnostics > Debugging	5-23
hisl_0306: Configuration Parameters > Diagnostics > Connectivity > Signals	5-25
hisl_0307: Configuration Parameters > Diagnostics > Connectivity > Buses	5-26
hisl_0308: Configuration Parameters > Diagnostics > Connectivity > Function calls	5-28
hisl_0309: Configuration Parameters > Diagnostics > Type Conversion	5-29
hisl_0310: Configuration Parameters > Diagnostics > Model Referencing	5-31

hisl_0311: Configuration Parameters > Diagnostics > Stateflow	5-32
hisl_0314: Configuration Parameters > Diagnostics > Data Validity > Signals	5-34
Model Referencing	5-37
hisl_0037: Configuration Parameters > Model Referencing ..	5-37
Code Generation	5-39
hisl_0045: Configuration Parameters > Math and Data Types > Implement logic signals as Boolean data (vs. double)	5-39
hisl_0046: Configuration Parameters > Code Generation > Optimization > Block reduction	5-41
hisl_0051: Configuration Parameters > Code Generation > Optimization > Loop unrolling threshold	5-43
hisl_0052: Configuration Parameters > Code Generation > Optimization > Data initialization	5-44
hisl_0053: Configuration Parameters > Code Generation > Optimization > Remove code from floating-point to integer conversions that wraps out-of-range values	5-46
hisl_0054: Configuration Parameters > Code Generation > Optimization > Remove code that protects against division arithmetic exceptions	5-48
hisl_0056: Configuration Parameters > Code Generation > Optimization > Optimize using the specified minimum and maximum values	5-49
hisl_0038: Configuration Parameters > Code Generation > Comments	5-51
hisl_0039: Configuration Parameters > Code Generation > Interface	5-53
hisl_0047: Configuration Parameters > Code Generation > Code Style	5-55
hisl_0049: Configuration Parameters > Code Generation > Symbols	5-57

Naming Considerations

6

Naming Considerations	6-2
hisl_0031: Model file names	6-2

7 MISRA C:2012 Compliance Considerations

Modeling Style	7-2
hisl_0061: Unique identifiers for clarity	7-2
hisl_0062: Global variables in graphical functions	7-8
hisl_0063: Length of user-defined object names to improve MISRA C:2012 compliance	7-10
hisl_0201: Define reserved keywords to improve MISRA C:2012 compliance	7-12
Block Usage	7-13
hisl_0020: Blocks not recommended for MISRA C:2012 compliance	7-13
hisl_0101: Avoid invariant comparison operations to improve MISRA C:2012 compliance	7-16
hisl_0102: Data type of loop control variables to improve MISRA C:2012 compliance	7-20
Configuration Settings	7-21
hisl_0060: Configuration parameters that improve MISRA C: 2012 compliance	7-21
Stateflow Chart Considerations	7-26
hisf_0064: Shift operations for Stateflow data to improve code compliance	7-26
hisf_0065: Type cast operations in Stateflow to improve code compliance	7-28
hisf_0211: Protect against use of unary operators in Stateflow Charts to improve code compliance	7-29
hisf_0213: Protect against divide-by-zero calculations in Stateflow charts to improve MISRA C:2012 compliance ..	7-31

Requirement Considerations	8-2
hisl_0070: Placement of requirement links in a model	8-2

Introduction

- “Motivation” on page 1-2
- “Guideline Template” on page 1-3
- “Model Advisor Checks for High-Integrity Modeling Guidelines” on page 1-4

Motivation

MathWorks intends the guidelines for engineers developing models and generating code for high-integrity systems using Model-Based Design with MathWorks products. The guidelines provide recommendations for creating Simulink models that are complete, unambiguous, statically deterministic, robust, and verifiable. The guidelines focus on model settings, block usage, and block parameters that impact simulation behavior or code generated by the Embedded Coder® product.

These guidelines do not assume that you use a particular safety or certification standard. The guidelines reference some safety standards where applicable, including:

- DO-178C / DO-331
- IEC 61508
- IEC 62304
- ISO 26262
- EN 50128
- MISRA C

The guidelines might also be applicable to related standards, including IEC 62304, and DO-254.

You can use the Model Advisor to support adhering to these guidelines. Each guideline lists the checks that are applicable to that guideline, or to parts of that guideline.

The guidelines do not address model style or development processes. For more information about creating models in a way that improves consistency, clarity, and readability, see the “MAAB Control Algorithm Modeling” guidelines. Development process guidance and additional information for specific standards is available with the IEC Certification Kit (for ISO 26262 and IEC 61508) and DO Qualification Kit (for DO-178) products.

Disclaimer While adhering to the recommendations in the guidelines will reduce the risk that an error is introduced during development and not be detected, it is not a guarantee that the system being developed will be safe. Conversely, if some of the recommendations in the guidelines are not followed, it does not mean that the system being developed will be unsafe.

Guideline Template

Guideline descriptions are documented, using the following template. Companies that want to create additional guidelines are encouraged to use the same template.

ID: Title	<i>XX_nnnn</i> : Title of the guideline (unique, short)
Description	Description of the guideline
Prerequisites	Links to guidelines that are prerequisites to this guideline (ID: Title)
Notes	Notes for using the guideline
Rationale	Rationale for providing the guideline
Model Advisor Check	Title of and link to the corresponding Model Advisor check, if a check exists
References	References to standards that apply to guideline
See Also	Links to additional information
Last Changed	Version number of last change
Examples	Guideline examples

Model Advisor Checks for High-Integrity Modeling Guidelines

Simulink Check includes Model Advisor checks for compliance with safety standards referenced in the high-integrity guidelines, including:

- DO-178C / DO-331
- IEC 61508
- IEC 62304
- ISO 26262
- EN 50128

The high-integrity guidelines and corresponding Model Advisor checks are summarized in the table. For the guidelines that do not have Model Advisor checks, it is not possible to automate checking of the guideline. Guidelines without a corresponding check are noted as not applicable.

Run the checks from these Model Advisor folders:

- **Modeling Standards for DO-178C/DO-331 > High-Integrity Systems**
- **Modeling Standards for IEC 61508 > High-Integrity Systems**
- **Modeling Standards for IEC 62304 > High-Integrity Systems**
- **Modeling Standards for EN 50128 > High-Integrity Systems**
- **Modeling Standards for ISO 26262 > High-Integrity Systems**

For information on using the Model Advisor, see Run Model Checks.

High-Integrity Modeling Guideline	Model Advisor Checks
hisl_0001: Usage of Abs block	DO-178C/DO-331: Check usage of Math Operations blocks IEC 61508, IEC 62304, EN 50128, and ISO 26262: Check usage of Math Operations blocks

High-Integrity Modeling Guideline	Model Advisor Checks
hisl_0002: Usage of Math Function blocks (rem and reciprocal)	DO-178C/DO-331: Check usage of Math Operations blocks IEC 61508, IEC 62304, EN 50128, and ISO 26262: Check usage of Math Operations blocks
hisl_0003: Usage of Square Root blocks	Not applicable
hisl_0004: Usage of Math Function blocks (natural logarithm and base 10 logarithm)	DO-178C/DO-331: Check usage of Math Operations blocks IEC 61508, IEC 62304, EN 50128, and ISO 26262: Check usage of Math Operations blocks
hisl_0005: Usage of Product blocks	DO-178C/DO-331: Check safety-related diagnostic settings for signal data IEC 61508, IEC 62304, EN 50128, and ISO 26262: Check safety-related diagnostic settings for signal data
hisl_0006: Usage of While Iterator blocks	DO-178C/DO-331: Check usage of Ports and Subsystems blocks IEC 61508, IEC 62304, EN 50128, and ISO 26262: Check usage of Ports and Subsystems blocks
hisl_0007: Usage of While Iterator subsystems	DO-178C/DO-331: Check usage of Ports and Subsystems blocks IEC 61508, IEC 62304, EN 50128, and ISO 26262: Check usage of Ports and Subsystems blocks
hisl_0008: Usage of For Iterator Blocks	DO-178C/DO-331: Check usage of Ports and Subsystems blocks IEC 61508, IEC 62304, EN 50128, and ISO 26262: Check usage of Ports and Subsystems blocks

High-Integrity Modeling Guideline	Model Advisor Checks
hisl_0009: Usage of For Iterator Subsystem blocks	DO-178C/DO-331: Check usage of Ports and Subsystems blocks IEC 61508, IEC 62304, EN 50128, and ISO 26262: Check usage of Ports and Subsystems blocks
hisl_0010: Usage of If blocks and If Action Subsystem blocks	DO-178C/DO-331: Check usage of Ports and Subsystems blocks IEC 61508, IEC 62304, EN 50128, and ISO 26262: Check usage of Ports and Subsystems blocks
hisl_0011: Usage of Switch Case blocks and Action Subsystem blocks	DO-178C/DO-331: Check usage of Ports and Subsystems blocks IEC 61508, IEC 62304, EN 50128, and ISO 26262: Check usage of Ports and Subsystems blocks
hisl_0012: Usage of conditionally executed subsystems	Not applicable
hisl_0013: Usage of data store blocks	DO-178C/DO-331: Check safety-related diagnostic settings for data store memory IEC 61508, IEC 62304, EN 50128, and ISO 26262: Check safety-related diagnostic settings for data store memory
hisl_0015: Usage of Merge blocks	Not applicable
hisl_0016: Usage of blocks that compute relational operators	DO-178C/DO-331: Check usage of Logic and Bit Operations blocks IEC 61508, IEC 62304, EN 50128, and ISO 26262: Check usage of Logic and Bit Operations blocks
hisl_0017: Usage of blocks that compute relational operators (2)	DO-178C/DO-331: Check usage of Logic and Bit Operations blocks IEC 61508, IEC 62304, EN 50128, and ISO 26262: Check usage of Logic and Bit Operations blocks

High-Integrity Modeling Guideline	Model Advisor Checks
hisl_0018: Usage of Logical Operator block	DO-178C/DO-331: Check usage of Logic and Bit Operations blocks IEC 61508, IEC 62304, EN 50128, and ISO 26262: Check usage of Logic and Bit Operations blocks
hisl_0019: Usage of Bitwise Operator block	Not applicable
hisl_0020: Blocks not recommended for MISRA C:2012 compliance	DO-178C/DO-331: Check for blocks not recommended for MISRA C:2012 DO-178C/DO-331: Check for blocks not recommended for C/C++ production code deployment IEC 61508, IEC 62304, EN 50128, and ISO 26262: Check for blocks not recommended for MISRA C: 2012 IEC 61508, IEC 62304, EN 50128, and ISO 26262: Check for blocks not recommended for C/C++ production code deployment
hisl_0021: Consistent vector indexing method	DO-178C/DO-331: Check for inconsistent vector indexing methods IEC 61508, IEC 62304, EN 50128, and ISO 26262: Check for inconsistent vector indexing methods
hisl_0022: Data type selection for index signals	Not applicable
hisl_0023: Verification of model and subsystem variants	DO-178C/DO-331: Check for variant blocks with 'Generate preprocessor conditionals' active IEC 61508, IEC 62304, EN 50128, and ISO 26262: Check for variant blocks with 'Generate preprocessor conditionals' active

High-Integrity Modeling Guideline	Model Advisor Checks
hisl_0024: Inport interface definition	DO-178C/DO-331: Check for root Inports with missing properties IEC 61508, IEC 62304, EN 50128, and ISO 26262: Check for root Inports with missing properties
hisl_0025: Design min/max specification of input interfaces	DO-178C/DO-331: Check for root Inports with missing range definitions IEC 61508, IEC 62304, EN 50128, and ISO 26262: Check for root Inports with missing range definitions
hisl_0026: Design min/max specification of output interfaces	DO-178C/DO-331: Check for root Outports with missing range definitions IEC 61508, IEC 62304, EN 50128, and ISO 26262: Check for root Outports with missing range definitions
hisl_0028: Usage of Reciprocal Square Root blocks	Not applicable
hisl_0029: Usage of Assignment blocks	DO-178C/DO-331: Check usage of Math Operations blocks IEC 61508, IEC 62304, EN 50128, and ISO 26262: Check usage of Math Operations blocks
hisl_0031: File and folder names	Not applicable
hisl_0032: Model object names	DO-178C/DO-331: Check model object names IEC 61508, IEC 62304, EN 50128, and ISO 26262: Check model object names
hisl_0033: Usage of Lookup Table blocks	DO-178C/DO-331: Check usage of lookup table blocks IEC 61508, IEC 62304, EN 50128, and ISO 26262: Check usage of lookup table blocks

High-Integrity Modeling Guideline	Model Advisor Checks
hisl_0034: Usage of Signal Routing blocks	DO-178C/DO-331: Check usage of Signal Routing blocks IEC 61508, IEC 62304, EN 50128, and ISO 26262: Check usage of Signal Routing blocks
hisl_0036: Configuration Parameters > Diagnostics > Saving	DO-178C/DO-331: Check safety-related diagnostic settings for saving IEC 61508, IEC 62304, EN 50128, and ISO 26262: Check safety-related diagnostic settings for saving
hisl_0037: Configuration Parameters > Model Referencing	DO-178C/DO-331: Check safety-related model referencing settings IEC 61508, IEC 62304, EN 50128, and ISO 26262: Check safety-related model referencing settings
hisl_0038: Configuration Parameters > Code Generation > Comments	DO-178C/DO-331: Check safety-related code generation settings IEC 61508, IEC 62304, EN 50128, and ISO 26262: Check safety-related code generation settings
hisl_0039: Configuration Parameters > Code Generation > Interface	DO-178C/DO-331: Check safety-related code generation settings IEC 61508, IEC 62304, EN 50128, and ISO 26262: Check safety-related code generation settings
hisl_0040: Configuration Parameters > Solver > Simulation time	DO-178C/DO-331: Check safety-related solver settings for simulation time IEC 61508, IEC 62304, EN 50128, and ISO 26262: Check safety-related solver settings for simulation time
hisl_0041: Configuration Parameters > Solver > Solver options	DO-178C/DO-331: Check safety-related solver settings for solver options IEC 61508, IEC 62304, EN 50128, and ISO 26262: Check safety-related solver settings for solver options

High-Integrity Modeling Guideline	Model Advisor Checks
hisl_0042: Configuration Parameters > Solver > Tasking and sample time options	DO-178C/DO-331: Check safety-related solver settings for tasking and sample-time IEC 61508, IEC 62304, EN 50128, and ISO 26262: Check safety-related solver settings for tasking and sample-time
hisl_0043: Configuration Parameters > Diagnostics > Solver	DO-178C/DO-331: Check safety-related diagnostic settings for solvers IEC 61508, IEC 62304, EN 50128, and ISO 26262: Check safety-related diagnostic settings for solvers
hisl_0044: Configuration Parameters > Diagnostics > Sample Time	DO-178C/DO-331: Check safety-related diagnostic settings for sample time IEC 61508, IEC 62304, EN 50128, and ISO 26262: Check safety-related diagnostic settings for sample time
hisl_0045: Configuration Parameters > Optimization > Implement logic signals as Boolean data (vs. double)	DO-178C/DO-331: Check safety-related optimization settings IEC 61508, IEC 62304, EN 50128, and ISO 26262: Check safety-related optimization settings
hisl_0046: Configuration Parameters > Optimization > Block reduction	DO-178C/DO-331: Check safety-related optimization settings IEC 61508, IEC 62304, EN 50128, and ISO 26262: Check safety-related optimization settings
hisl_0047: Configuration Parameters > Code Generation > Code Style	DO-178C/DO-331: Check safety-related code generation settings IEC 61508, IEC 62304, EN 50128, and ISO 26262: Check safety-related code generation settings

High-Integrity Modeling Guideline	Model Advisor Checks
hisl_0048: Configuration Parameters > Optimization > Application lifespan (days)	DO-178C/DO-331: Check safety-related optimization settings IEC 61508, IEC 62304, EN 50128, and ISO 26262: Check safety-related optimization settings
hisl_0049: Configuration Parameters > Code Generation > Symbols	DO-178C/DO-331: Check safety-related code generation settings IEC 61508, IEC 62304, EN 50128, and ISO 26262: Check safety-related code generation settings
hisl_0051: Configuration Parameters > Optimization > Loop unrolling threshold	DO-178C/DO-331: Check safety-related optimization settings for Loop unrolling threshold IEC 61508, IEC 62304, EN 50128, and ISO 26262: Check safety-related optimization settings for Loop unrolling threshold
hisl_0052: Configuration Parameters > Optimization > Data initialization	DO-178C/DO-331: Check safety-related optimization settings IEC 61508, IEC 62304, EN 50128, and ISO 26262: Check safety-related optimization settings
hisl_0053: Configuration Parameters > Optimization > Remove code from floating-point to integer conversions that wraps out-of-range values	DO-178C/DO-331: Check safety-related optimization settings IEC 61508, IEC 62304, EN 50128, and ISO 26262: Check safety-related optimization settings
hisl_0054: Configuration Parameters > Optimization > Remove code that protects against division arithmetic exceptions	DO-178C/DO-331: Check safety-related optimization settings IEC 61508, IEC 62304, EN 50128, and ISO 26262: Check safety-related optimization settings
hisl_0056: Configuration Parameters > Optimization > Optimize using the specified minimum and maximum values	DO-178C/DO-331: Check safety-related optimization settings IEC 61508, IEC 62304, EN 50128, and ISO 26262: Check safety-related optimization settings

High-Integrity Modeling Guideline	Model Advisor Checks
hisl_0060: Configuration parameters that improve MISRA C:2012 compliance	DO-178C/DO-331: Check configuration parameters for MISRA C:2012 IEC 61508, IEC 62304, EN 50128, and ISO 26262: Check configuration parameters for MISRA C:2012 In Modeling Standards for MISRA C:2012 folder: Check for bitwise operations on signed integers
hisl_0061: Unique identifiers for clarity	DO-178C/DO-331: Check Stateflow charts for uniquely defined data objects DO-178C/DO-331: Check usage of Stateflow constructs IEC 61508, IEC 62304, EN 50128, and ISO 26262: Check Stateflow charts for uniquely defined data objects IEC 61508, IEC 62304, EN 50128, and ISO 26262: Check usage of Stateflow constructs
hisl_0062: Global variables in graphical functions	Not applicable
hisl_0063: Length of user-defined object names to improve MISRA C:2012 compliance	Not applicable
hisl_0066: Usage of Gain blocks	DO-178C/DO-331: Check usage of Math Operations blocks IEC 61508, IEC 62304, EN 50128, and ISO 26262: Check usage of Math Operations blocks
hisl_0070: Placement of requirement links in a model	DO-178C/DO-331: Check for model elements that do not link to requirements IEC 61508, IEC 62304, EN 50128, and ISO 26262: Check for model elements that do not link to requirements

High-Integrity Modeling Guideline	Model Advisor Checks
hisl_0101: Avoid invariant comparison operations to improve MISRA C:2012 compliance	Not applicable
hisl_0102: Data type of loop control variables to improve MISRA C:2012 compliance	Not applicable
hisl_0201: Define reserved keywords to improve MISRA C: 2012 compliance	Not applicable
hisl_0301: Configuration Parameters > Diagnostics > Compatibility	DO-178C/DO-331: Check safety-related diagnostic settings for compatibility IEC 61508, IEC 62304, EN 50128, and ISO 26262: Check safety-related diagnostic settings for compatibility
hisl_0302: Configuration Parameters > Diagnostics > Data Validity > Parameters	DO-178C/DO-331: Check safety-related diagnostic settings for parameters IEC 61508, IEC 62304, EN 50128, and ISO 26262: Check safety-related diagnostic settings for parameters
hisl_0303: Configuration Parameters > Diagnostics > Merge block	DO-178C/DO-331: Check safety-related diagnostic settings for Merge blocks IEC 61508, IEC 62304, EN 50128, and ISO 26262: Check safety-related diagnostic settings for Merge blocks
hisl_0304: Configuration Parameters > Diagnostics > Model initialization	DO-178C/DO-331: Check safety-related diagnostic settings for model initialization IEC 61508, IEC 62304, EN 50128, and ISO 26262: Check safety-related diagnostic settings for model initialization

High-Integrity Modeling Guideline	Model Advisor Checks
hisl_0305: Configuration Parameters > Diagnostics > Debugging	DO-178C/DO-331: Check safety-related diagnostic settings for data used for debugging IEC 61508, IEC 62304, EN 50128, and ISO 26262: Check safety-related diagnostic settings for data used for debugging
hisl_0306: Configuration Parameters > Diagnostics > Connectivity > Signals	DO-178C/DO-331: Check safety-related diagnostic settings for signal connectivity IEC 61508, IEC 62304, EN 50128, and ISO 26262: Check safety-related diagnostic settings for signal connectivity
hisl_0307: Configuration Parameters > Diagnostics > Connectivity > Buses	DO-178C/DO-331: Check safety-related diagnostic settings for bus connectivity IEC 61508, IEC 62304, EN 50128, and ISO 26262: Check safety-related diagnostic settings for bus connectivity
hisl_0308: Configuration Parameters > Diagnostics > Connectivity > Function calls	DO-178C/DO-331: Check safety-related diagnostic settings that apply to function-call connectivity IEC 61508, IEC 62304, EN 50128, and ISO 26262: Check safety-related diagnostic settings that apply to function-call connectivity
hisl_0309: Configuration Parameters > Diagnostics > Type Conversion	DO-178C/DO-331: Check safety-related diagnostic settings for type conversions IEC 61508, IEC 62304, EN 50128, and ISO 26262: Check safety-related diagnostic settings for type conversions
hisl_0310: Configuration Parameters > Diagnostics > Model Referencing	DO-178C/DO-331: Check safety-related diagnostic settings for model referencing IEC 61508, IEC 62304, EN 50128, and ISO 26262: Check safety-related diagnostic settings for model referencing

High-Integrity Modeling Guideline	Model Advisor Checks
hisl_0311: Configuration Parameters > Diagnostics > Stateflow	<p>DO-178C/DO-331: Check safety-related diagnostic settings for Stateflow</p> <p>IEC 61508, IEC 62304, EN 50128, and ISO 26262: Check safety-related diagnostic settings for Stateflow</p>
hisl_0314: Configuration Parameters > Diagnostics > Data Validity > Signals	<p>DO-178C/DO-331: Check safety-related diagnostic settings for signal data</p> <p>IEC 61508, IEC 62304, EN 50128, and ISO 26262: Check safety-related diagnostic settings for signal data</p>
hisf_0001: Mealy and Moore semantics	<p>DO-178C/DO-331: Check state machine type of Stateflow charts</p> <p>IEC 61508, IEC 62304, EN 50128, and ISO 26262: Check state machine type of Stateflow charts</p>
hisf_0002: User-specified state/transition execution order	<p>DO-178C/DO-331: Check Stateflow charts for ordering of states and transitions</p> <p>DO-178C/DO-331: Check usage of Stateflow constructs</p> <p>IEC 61508, IEC 62304, EN 50128, and ISO 26262: Check Stateflow charts for ordering of states and transitions</p> <p>IEC 61508, IEC 62304, EN 50128, and ISO 26262: Check usage of Stateflow constructs</p>
hisf_0003: Usage of bitwise operations	<p>In Modeling Standards for MAAB > Stateflow folder: Check for bitwise operations in Stateflow charts</p> <p>In Modeling Standards for JMAAB > Stateflow folder: Check for bitwise operations in Stateflow charts</p>

High-Integrity Modeling Guideline	Model Advisor Checks
hisf_0004: Usage of recursive behavior	Not applicable
hisf_0007: Usage of junction conditions (maintaining mutual exclusion)	Not applicable
hisf_0009: Strong data typing (Simulink and Stateflow boundary)	DO-178C/DO-331: Check usage of Stateflow constructs IEC 61508, IEC 62304, EN 50128, and ISO 26262: Check usage of Stateflow constructs
hisf_0011: Stateflow debugging settings	DO-178C/DO-331: Check Stateflow debugging options DO-178C/DO-331: Check usage of Stateflow constructs IEC 61508, IEC 62304, EN 50128, and ISO 26262: Check Stateflow debugging options IEC 61508, IEC 62304, EN 50128, and ISO 26262: Check usage of Stateflow constructs
hisf_0013: Usage of transition paths (crossing parallel state boundaries)	DO-178C/DO-331: Check Stateflow charts for transition paths that cross parallel state boundaries IEC 61508, IEC 62304, EN 50128, and ISO 26262: Check Stateflow charts for transition paths that cross parallel state boundaries
hisf_0014: Usage of transition paths (passing through states)	Not applicable
hisf_0015: Strong data typing (casting variables and parameters in expressions)	DO-178C/DO-331: Check Stateflow charts for strong data typing IEC 61508, IEC 62304, EN 50128, and ISO 26262: Check Stateflow charts for strong data typing

High-Integrity Modeling Guideline	Model Advisor Checks
hisf_0016: Stateflow port names	DO-178C/DO-331: Check usage of Stateflow constructs IEC 61508, IEC 62304, EN 50128, and ISO 26262: Check usage of Stateflow constructs
hisf_0017: Stateflow data object scoping	DO-178C/DO-331: Check usage of Stateflow constructs IEC 61508, IEC 62304, EN 50128, and ISO 26262: Check usage of Stateflow constructs
hisf_0064: Shift operations for Stateflow data to improve code compliance	DO-178C/DO-331: Check usage of shift operations for Stateflow data IEC 61508, IEC 62304, EN 50128, and ISO 26262: Check usage of shift operations for Stateflow data
hisf_0065: Type cast operations in Stateflow to improve code compliance	DO-178C/DO-331: Check assignment operations in Stateflow charts IEC 61508, IEC 62304, EN 50128, and ISO 26262: Check assignment operations in Stateflow charts
hisf_0211: Protect against use of unary operators in Stateflow Charts to improve code compliance	DO-178C/DO-331: Check Stateflow charts for unary operators IEC 61508, IEC 62304, EN 50128, and ISO 26262: Check Stateflow charts for unary operators
hisf_0213: Protect against divide-by-zero calculations in Stateflow charts to improve MISRA C:2012 compliance	Not applicable
himl_0001: Usage of standardized MATLAB function headers	Not applicable

High-Integrity Modeling Guideline	Model Advisor Checks
himl_0002: Strong data typing at MATLAB function boundaries	DO-178C/DO-331: Check for MATLAB Function interfaces with inherited properties IEC 61508, IEC 62304, EN 50128, and ISO 26262: Check for MATLAB Function interfaces with inherited properties
himl_0003: Limitation of MATLAB function complexity	DO-178C/DO-331: Check MATLAB Function metrics IEC 61508, IEC 62304, EN 50128, and ISO 26262: Check MATLAB Function metrics
himl_0004: MATLAB Code Analyzer recommendations for code generation	DO-178C/DO-331: Check MATLAB Code Analyzer messages IEC 61508, IEC 62304, EN 50128, and ISO 26262: Check MATLAB Code Analyzer messages
himl_0005: Usage of global variables in MATLAB functions	DO-178C/DO-331: Check MATLAB code for global variables IEC 61508, IEC 62304, EN 50128, and ISO 26262: Check MATLAB code for global variables
himl_0006: MATLAB code if / elseif / else patterns	Not applicable
himl_0007: MATLAB code switch / case / otherwise patterns	Not applicable
himl_0008: MATLAB code relational operator data types	Not applicable
himl_0009: MATLAB code with equal / not equal relational operators	Not applicable
himl_0010: MATLAB code with logical operators and functions	Not applicable

Simulink Block Considerations

- “Math Operations” on page 2-2
- “Ports & Subsystems” on page 2-21
- “Signal Routing” on page 2-39
- “Logic and Bit Operations” on page 2-50
- “Lookup Table Blocks” on page 2-57

Math Operations

In this section...
“hisl_0001: Usage of Abs block” on page 2-2
“hisl_0002: Usage of Math Function blocks (rem and reciprocal)” on page 2-4
“hisl_0003: Usage of Square Root blocks” on page 2-6
“hisl_0028: Usage of Reciprocal Square Root blocks” on page 2-7
“hisl_0004: Usage of Math Function blocks (natural logarithm and base 10 logarithm)” on page 2-9
“hisl_0005: Usage of Product blocks” on page 2-13
“hisl_0029: Usage of Assignment blocks” on page 2-15
“hisl_0066: Usage of Gain blocks” on page 2-19

hisl_0001: Usage of Abs block

ID: Title	hisl_0001: Usage of Abs block	
Description	To support robustness of generated code, when using the Abs block,	
	A	Avoid Boolean and unsigned integer data types as inputs to the Abs block.
	B	In the Abs block parameter dialog box, select Saturate on integer overflow .
Notes	<p>The Abs block does not support Boolean data types. Specifying an unsigned input data type, might optimize the Abs block out of the generated code, resulting in a block you cannot trace to the generated code.</p> <p>For signed data types, Simulink does not represent the absolute value of the most negative value. When you select Saturate on integer overflow, the absolute value of the data type saturates to the most positive representable value. When you clear Saturate on integer overflow, absolute value calculations in the simulation and generated code might not be consistent or expected.</p>	
Rationale	A	Support generation of traceable code.

ID: Title	hisl_0001: Usage of Abs block	
	B	Achieve consistent and expected behavior of model simulation and generated code.
Model Advisor Checks	<ul style="list-style-type: none"> • By Task > Modeling Standards for DO-178C/DO-331 > High-Integrity Systems > Simulink > Check usage of Math Operations blocks • By Task > Modeling Standards for IEC 61508 > High-Integrity Systems > Simulink > Check usage of Math Operations blocks • By Task > Modeling Standards for IEC 62304 > High-Integrity Systems > Simulink > Check usage of Math Operations blocks • By Task > Modeling Standards for EN 50128 > High-Integrity Systems > Simulink > Check usage of Math Operations blocks • By Task > Modeling Standards for ISO 26262 > High-Integrity Systems > Simulink > Check usage of Math Operations blocks <p>For DO-178C/DO-331 check details, see Check usage of Math Operations blocks.</p> <p>For IEC 61508, IEC 62304, EN 50128, and ISO 26262 check details, see Check usage of Math Operations blocks.</p>	
References	<ul style="list-style-type: none"> • IEC 61508-3, Table A.3 (3) 'Language subset' • IEC 61508-3, Table A.4 (3) 'Defensive programming' • IEC 61508-3, Table A.3 (2) 'Strongly typed programming language' • IEC 61508-3, Table B.8 (3) 'Control Flow Analysis' • IEC 62304, 5.5.3 - Software Unit acceptance criteria • ISO 26262-6, Table 1 (1b) 'Use of language subsets' • ISO 26262-6, Table 1 (1d) 'Use of defensive implementation techniques' • ISO 26262-6, Table 9 (1e) 'Control flow analysis' • EN 50128, Table A.4 (11) 'Language Subset' • EN 50128, Table A.3 (1) 'Defensive Programming' • EN 50128, Table A.4 (8) 'Strongly Typed Programming Language' • EN 50128, Table A.19 (3) 'Control Flow Analysis' • DO-331, Section MB.6.3.2.d 'Low-level requirements are verifiable' • MISRA C:2012, Dir 4.1 	
Last Changed	R2016a	

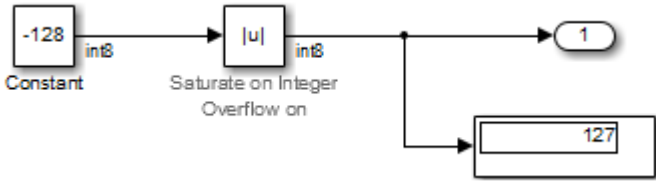
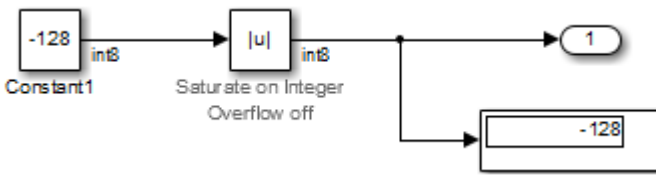
ID: Title	hisl_0001: Usage of Abs block
Examples	<div style="text-align: center;">  <p>The diagram shows a constant block with the value -128. Its output is connected to an Abs block. The Abs block has the text 'Saturate on Integer Overflow on' below it. The output of the Abs block is connected to a scope block, which displays the value 127.</p> </div> <p>Recommended</p> <div style="text-align: center;">  <p>The diagram shows a constant block with the value -128. Its output is connected to an Abs block. The Abs block has the text 'Saturate on Integer Overflow off' below it. The output of the Abs block is connected to a scope block, which displays the value -128.</p> </div> <p>Not Recommended</p>

hisl_0002: Usage of Math Function blocks (rem and reciprocal)

ID: Title	hisl_0002: Usage of Math Function blocks (rem and reciprocal)	
Description	To support robustness of generated code, when using the Math Function block with remainder-after-division (<code>rem</code>) or reciprocal (<code>reciprocal</code>) functions:	
	A	Protect the input of the <code>reciprocal</code> function from going to zero.
	B	Protect the second input of the <code>rem</code> function from going to zero.
Note	You can get a divide-by-zero operation, resulting in an infinite (<code>Inf</code>) output value for the <code>reciprocal</code> function, or a Not-a-Number (<code>NaN</code>) output value for the <code>rem</code> function. To avoid overflows or undefined values, protect the corresponding input from going to zero.	
Rationale	A, B	Protect against overflows and undefined numerical results.

ID: Title	hisl_0002: Usage of Math Function blocks (rem and reciprocal)
Model Advisor Checks	<ul style="list-style-type: none"> • By Task > Modeling Standards for DO-178C/DO-331 > High-Integrity Systems > Simulink > Check usage of Math Operations blocks • By Task > Modeling Standards for IEC 61508 > High-Integrity Systems > Simulink > Check usage of Math Operations blocks • By Task > Modeling Standards for IEC 62304 > High-Integrity Systems > Simulink > Check usage of Math Operations blocks • By Task > Modeling Standards for EN 50128 > High-Integrity Systems > Simulink > Check usage of Math Operations blocks • By Task > Modeling Standards for ISO 26262 > High-Integrity Systems > Simulink > Check usage of Math Operations blocks <p>For DO-178C/DO-331 check details, see Check usage of Math Operations blocks.</p> <p>For IEC 61508, IEC 62304, EN 50128, and ISO 26262 check details, see Check usage of Math Operations blocks.</p>
References	<ul style="list-style-type: none"> • IEC 61508-3, Table A.3 (3) 'Language subset' • IEC 61508-3, Table A.4 (3) 'Defensive programming' • IEC 62304, 5.5.3 - Software Unit acceptance criteria • ISO 26262-6, Table 1(b) 'Use of language subsets' • ISO 26262-6, Table 1(d) 'Use of defensive implementation techniques' • EN 50128, Table A.4 (11) 'Language Subset' • EN 50128, Table A.3 (1) 'Defensive Programming' • DO-331, Section MB.6.3.2.g 'Algorithms are accurate' • MISRA C:2012, Dir 4.1
Last Changed	R2017b

ID: Title	hisl_0002: Usage of Math Function blocks (rem and reciprocal)
Examples	<p>In the following example, when the input signal oscillates around zero, the output exhibits a large change in value. You need further protection against the large change in value.</p> <p>The figure contains two Simulink diagrams. Both diagrams start with a signal entering a switch block. The switch block has three inputs: a top input, a middle input, and a bottom input. The top input is connected to a constant block with the value '1' (top diagram) or '3' (bottom diagram). The middle input is connected to a '==' block, which also receives a '0' constant input. The bottom input is connected to an 'eps' block. The output of the switch block goes to a '1/u' reciprocal block (top diagram) or a 'rem' block (bottom diagram). The 'rem' block also receives a '2' constant input. The final outputs are '1' (top diagram) and '2' (bottom diagram).</p>

hisl_0003: Usage of Square Root blocks

ID: Title	hisl_0003: Usage of Square Root blocks	
Description	To support robustness of generated code, when using the Square Root block, do one of the following:	
	A	Account for complex numbers as the output.
	B	Protect the input from going negative.

ID: Title	hisl_0003: Usage of Square Root blocks	
Rationale	A, B	Avoid undesirable results in generated code.
References	<ul style="list-style-type: none"> • IEC 61508-3, Table A.3 (3) 'Language subset' • IEC 61508-3, Table A.4 (3) 'Defensive programming' • IEC 62304, 5.5.3 - Software Unit acceptance criteria • ISO 26262-6, Table 1(b) 'Use of language subsets' • ISO 26262-6, Table 1(d) 'Use of defensive implementation techniques' • EN 50128, Table A.4 (11) 'Language Subset' • EN 50128, Table A.3 (1) 'Defensive Programming' • DO-331, Section MB.6.3.2.g 'Algorithms are accurate' • MISRA C:2012, Dir 4.1 	
Last Changed	R2016a	
Examples		

hisl_0028: Usage of Reciprocal Square Root blocks

ID: Title	hisl_0028: Usage of Reciprocal Square Root blocks	
Description	To support robustness of generated code, when using the Reciprocal Square Root block, do one of the following:	
	A	Protect the input from going negative.

ID: Title	hisl_0028: Usage of Reciprocal Square Root blocks	
	B	Protect the input from going to zero.
Note	You can get a divide-by-zero operation, resulting in an (Inf) output value for the reciprocal function. To avoid overflows or undefined values, protect the corresponding input from going to zero.	
Rationale	A, B	Avoid undesirable results in generated code.
References	<ul style="list-style-type: none"> • IEC 61508-3, Table A.3 (3) 'Language subset' • IEC 61508-3, Table A.4 (3) 'Defensive programming' • IEC 62304, 5.5.3 - Software Unit acceptance criteria • ISO 26262-6, Table 1(b) 'Use of language subsets' • ISO 26262-6, Table 1(d) 'Use of defensive implementation techniques' • EN 50128, Table A.4 (11) 'Language Subset' • EN 50128, Table A.3 (1) 'Defensive Programming' • DO-331, Section MB.6.3.2.g 'Algorithms are accurate' • MISRA C:2012, Dir 4.1 	
Last Changed	R2016a	
Examples		

hisl_0004: Usage of Math Function blocks (natural logarithm and base 10 logarithm)

ID: Title	hisl_0004: Usage of Math Function blocks (natural logarithm and base 10 logarithm)	
Description	To support robustness of generated code, when using the Math Function block with natural logarithm (\log) or base 10 logarithm (\log_{10}) function parameters,	
	A	Protect the input from going negative.
	B	Protect the input from equaling zero.
	C	Account for complex numbers as the output value.
Notes	If you set the output data type to complex, the natural logarithm and base 10 logarithm functions output complex values for negative input values. If you set the output data type to real, the functions output NAN for negative numbers, and minus infinity ($-\text{inf}$) for zero values.	
Rationale	A, B, C	Support generation of robust code.
Model Advisor Checks	<ul style="list-style-type: none"> • By Task > Modeling Standards for DO-178C/DO-331 > High-Integrity Systems > Simulink > Check usage of Math Operations blocks • By Task > Modeling Standards for IEC 61508 > High-Integrity Systems > Simulink > Check usage of Math Operations blocks • By Task > Modeling Standards for IEC 62304 > High-Integrity Systems > Simulink > Check usage of Math Operations blocks • By Task > Modeling Standards for EN 50128 > High-Integrity Systems > Simulink > Check usage of Math Operations blocks • By Task > Modeling Standards for ISO 26262 > High-Integrity Systems > Simulink > Check usage of Math Operations blocks <p>For DO-178C/DO-331 check details, see Check usage of Math Operations blocks.</p> <p>For IEC 61508, IEC 62304, EN 50128, and ISO 26262 check details, see Check usage of Math Operations blocks.</p>	

ID: Title	hisl_0004: Usage of Math Function blocks (natural logarithm and base 10 logarithm)
References	<ul style="list-style-type: none">• IEC 61508-3, Table A.3 (3) 'Language subset'• IEC 61508-3, Table A.4 (3) 'Defensive programming'• IEC 62304, 5.5.3 - Software Unit acceptance criteria• ISO 26262-6, Table 1(b) 'Use of language subsets'• ISO 26262-6, Table 1(d) 'Use of defensive implementation techniques'• EN 50128, Table A.4 (11) 'Language Subset'• EN 50128, Table A.3 (1) 'Defensive Programming'• DO-331, Section MB.6.3.2.g 'Algorithms are accurate'• MISRA C:2012, Dir 4.1
Last Changed	R2017b

ID: Title hisl_0004: Usage of Math Function blocks (natural logarithm and base 10 logarithm)

Examples

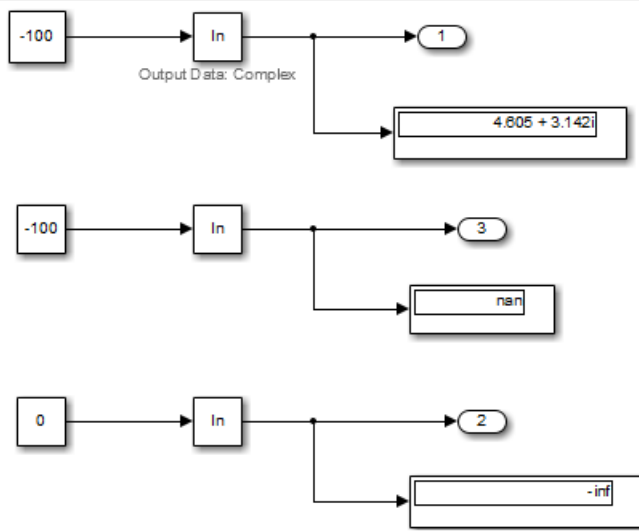

You can protect against:

- Negative numbers using an Abs block.
- Zero values using a combination of the MinMax block and a Constant block, with **Constant value** set to eps (epsilon).

The following example displays the resulting output for input values ranging from -100 to 100.

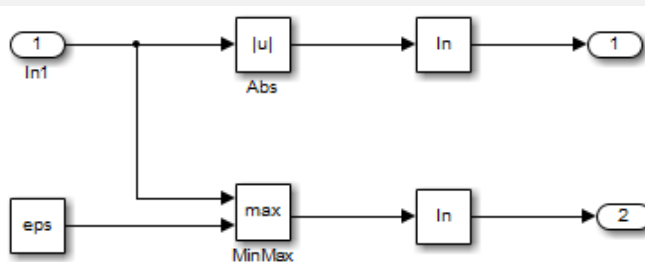

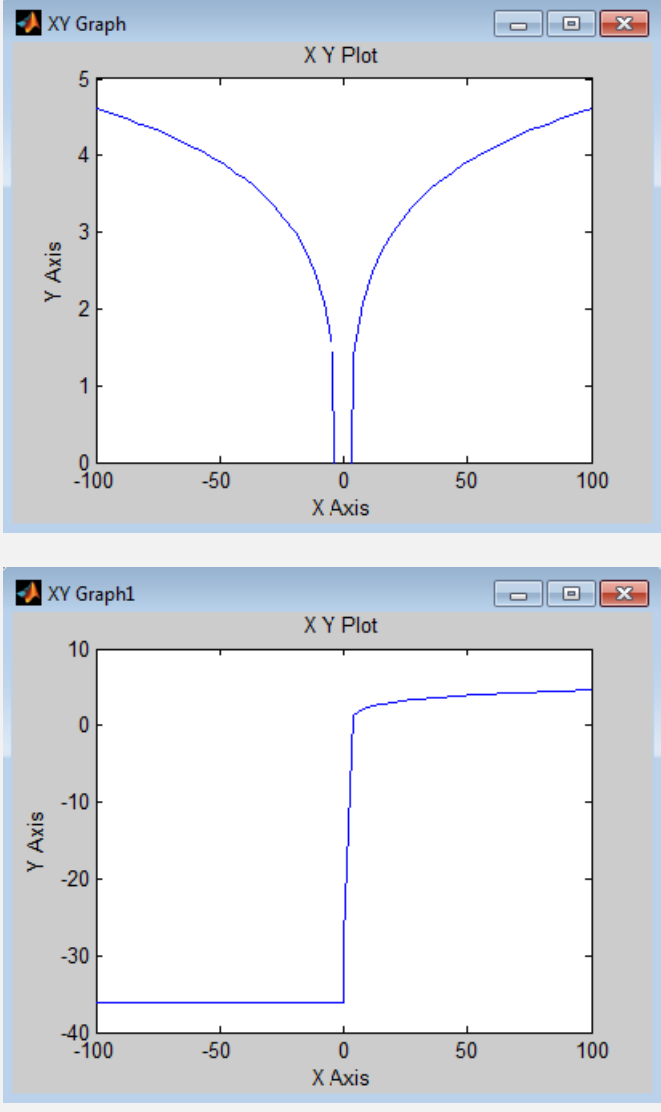
ID: Title	hisl_0004: Usage of Math Function blocks (natural logarithm and base 10 logarithm)
	 <p>The figure displays two Simulink XY Graph windows. The top window, titled 'XY Graph', shows a plot of a function with a vertical asymptote at x=0. The x-axis ranges from -100 to 100, and the y-axis ranges from 0 to 5. The curve is symmetric about the y-axis, with values increasing as x increases. The bottom window, titled 'XY Graph1', shows a plot of a step function. The x-axis ranges from -100 to 100, and the y-axis ranges from -40 to 10. The function is constant at approximately -35 for x < 0 and jumps to approximately 5 for x > 0.</p>

hisl_0005: Usage of Product blocks

ID: Title	hisl_0005: Usage of Product blocks	
Description	To support robustness of generated code, when using the Product block with divisor inputs,	
	A	In <code>Element-wise(.*)</code> mode, protect divisor inputs from going to zero.
	B	In <code>Matrix(*)</code> mode, protect divisor inputs from becoming singular input matrices.
	C	Set the model configuration parameter Diagnostics > Data Validity > Signals > Division by singular matrix to error.
Notes	<p>When using Product blocks for element-wise divisions, you might get a divide by zero, resulting in a NaN output. To avoid overflows, protect divisor inputs from going to zero.</p> <p>When using Product blocks to compute the inverse of a matrix, or a matrix division, you might get a divide by a singular matrix. This division results in a NaN output. To avoid overflows, protect divisor inputs from becoming singular input matrices.</p> <p>During simulation, while the software inverts one of the input values of a Product block that is in matrix multiplication mode, the Division by singular matrix diagnostic can detect a singular matrix.</p>	
Rationale	A, B, C	Protect against overflows.

ID: Title	hisl_0005: Usage of Product blocks
<p>Model Advisor Checks</p>	<ul style="list-style-type: none"> • By Task > Modeling Standards for DO-178C/DO-331 > High-Integrity Systems > Configuration > Check safety-related diagnostic settings for signal data • By Task > Modeling Standards for IEC 61508 > High-Integrity Systems > Configuration > Check safety-related diagnostic settings for signal data • By Task > Modeling Standards for IEC 62304 > High-Integrity Systems > Configuration > Check safety-related diagnostic settings for signal data • By Task > Modeling Standards for EN 50128 > High-Integrity Systems > Configuration > Check safety-related diagnostic settings for signal data • By Task > Modeling Standards for ISO 26262 > High-Integrity Systems > Configuration > Check safety-related diagnostic settings for signal data <p>For DO-178C/DO-331 check details, see Check safety-related diagnostic settings for signal data.</p> <p>For IEC 61508, IEC 62304, EN 50128, and ISO 26262 check details, see Check safety-related diagnostic settings for signal data.</p>

ID: Title	hisl_0005: Usage of Product blocks
References	<ul style="list-style-type: none"> • IEC 61508-3, Table A.3 (3) 'Language subset' • IEC 61508-3, Table A.4 (3) 'Defensive programming' • IEC 62304, 5.5.3 - Software Unit acceptance criteria • ISO 26262-6, Table 1 (1b) 'Use of language subsets' • ISO 26262-6, Table 1 (1d) 'Use of defensive implementation techniques' • EN 50128, Table A.4 (11) 'Language Subset' • EN 50128, Table A.3 (1) 'Defensive Programming' • DO-331, Section MB.6.4.2.2 'Robustness Test Cases' • DO-331, Section MB.6.4.3 'Requirements-Based Testing Methods' • DO-331, Section MB.6.3.1.e 'High-level requirements conform to standards' • DO-331, Section MB.6.3.2.e 'Low-level requirements conform to standards' • DO-331, Section MB.6.3.1.g 'Algorithms are accurate' • DO-331, Section MB.6.3.2.g 'Algorithms are accurate' • DO-331, Section MB.6.3.3.b 'Software architecture is consistent' • MISRA C:2012, Dir 4.1
Last Changed	R2017b

hisl_0029: Usage of Assignment blocks

ID: Title	hisl_0029: Usage of Assignment blocks
Description	To support robustness of generated code, when using the Assignment block, initialize array fields before their first use.
Notes	<p>If the output vector of the Assignment block is not initialized with an input to the block, elements of the vector might not be initialized in the generated code.</p> <p>When the Assignment block is used iteratively and all array field are assigned during one simulation time step, you do not need initialization input to the block.</p> <p>Accessing uninitialized elements of block output can result in unexpected behavior.</p>
Rationale	Avoid undesirable results in generated code.

ID: Title	hisl_0029: Usage of Assignment blocks
Model Advisor Checks	<ul style="list-style-type: none"> • By Task > Modeling Standards for DO-178C/DO-331 > High-Integrity Systems > Simulink > Check usage of Math Operations blocks • By Task > Modeling Standards for IEC 61508 > High-Integrity Systems > Simulink > Check usage of Math Operations blocks • By Task > Modeling Standards for IEC 62304 > High-Integrity Systems > Simulink > Check usage of Math Operations blocks • By Task > Modeling Standards for EN 50128 > High-Integrity Systems > Simulink > Check usage of Math Operations blocks • By Task > Modeling Standards for ISO 26262 > High-Integrity Systems > Simulink > Check usage of Math Operations blocks <p>For DO-178C/DO-331 check details, see Check usage of Math Operations blocks.</p> <p>For IEC 61508, IEC 62304, EN 50128, and ISO 26262 check details, see Check usage of Math Operations blocks.</p>
References	<ul style="list-style-type: none"> • IEC 61508-3, Table A.3 (3) 'Language subset' • IEC 61508-3, Table A.4 (3) 'Defensive programming' • IEC 61508-3, Table A.3 (2) 'Strongly typed programming language' • IEC 62304, 5.5.3 - Software Unit acceptance criteria • ISO 26262-6, Table 1(b) 'Use of language subsets' • ISO 26262-6, Table 1(d) 'Use of defensive implementation techniques' • EN 50128, Table A.4 (11) 'Language Subset' • EN 50128, Table A.3 (1) 'Defensive Programming' • EN 50128, Table A.4 (8) 'Strongly Typed Programming Language' • DO-331, Section MB.6.3.1.e 'High-level requirements conform to standards' • DO-331, Section MB.6.3.2.e 'Low-level requirements conform to standards' • MISRA C:2012, Rule 9.1
Last Changed	R2016a

ID: Title	hisl_0029: Usage of Assignment blocks
Examples	<div data-bbox="382 343 1184 534" style="border: 1px solid black; padding: 10px; margin-bottom: 10px;"> </div> <pre data-bbox="344 576 1065 986"> 31 /* Model step function */ 32 void Assignment1_step(void) 33 { 34 <u>real T</u> rtb_Assignment[2]; 35 36 /* Assignment: '<Root>/Assignment' incorporates: 37 * Constant: '<Root>/Constant' 38 * Inport: '<Root>/U3' 39 */ 40 rtb_Assignment[0] = <u>Assignment1</u> U.U3; 41 42 /* Output: '<Root>/Y2' */ 43 <u>Assignment1</u> Y.Y2 = rtb_Assignment[1]; 44 } </pre> <p data-bbox="338 1020 1264 1079">Not Recommended: No initialization input Y0 when block is not used iteratively</p> <div data-bbox="397 1177 1115 1402" style="border: 1px solid black; padding: 10px; margin-top: 10px;"> </div>

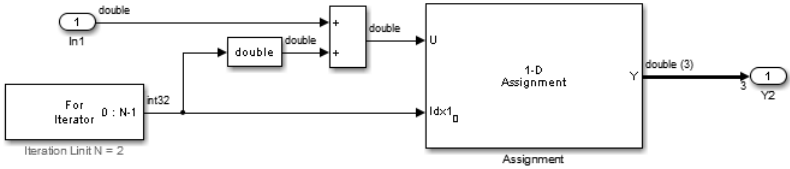
ID: Title	hisl_0029: Usage of Assignment blocks
	<pre data-bbox="347 302 1157 683"> /* Model step function */ 32 void Assignment2_step(void) 33 { 34 /* Assignment: '<Root>/Assignment' incorporates: 35 * Constant: '<Root>/Constant' 36 * Inport: '<Root>/In1' 37 * Inport: '<Root>/In2' 38 */ 39 Assignment2 Y.Y2[0] = 0.0; 40 Assignment2 Y.Y2[1] = 0.0; 41 Assignment2 Y.Y2[2] = 0.0; 42 Assignment2 Y.Y2[Assignment2 U.In2] = Assignment2 U.In1; 43 } </pre> <p data-bbox="338 718 1311 748">Recommended: Initialization input Y0 when block is not used iteratively</p> 

ID: Title	hisl_0029: Usage of Assignment blocks
	<pre data-bbox="341 295 1187 720"> /* Model step function */ 32 void Assignment3_step(void) 33 { 34 int32 T s1_iter; 35 36 /* Outputs for Iterator SubSystem: '<Root>/For Iterator Subsystem' incorporates: 37 * ForIterator: '<S1>/For Iterator' 38 */ 39 for (s1_iter = 0; s1_iter < 2; s1_iter++) { 40 /* Assignment: '<S1>/Assignment' incorporates: 41 * DataTypeConversion: '<S1>/Data Type Conversion' 42 * Inport: '<Root>/Ini' 43 * Sum: '<S1>/Add' 44 */ 45 Assignment3_Y.Out1[s1_iter] = Assignment3_U.In1 + ((real T)s1_iter); 46 } 47 48 /* End of Outputs for SubSystem: '<Root>/For Iterator Subsystem' */ 49 } </pre> <p data-bbox="341 755 1246 789">Recommended: Initialize array fields when block is used iteratively</p>

hisl_0066: Usage of Gain blocks

ID: Title	hisl_0066: Usage of Gain blocks
Description	To support traceability of generated code, the value of the Gain block must not resolve to 1.
Notes	<p data-bbox="385 1032 1261 1093">The code generation process can remove Gain values equal to 1 during optimization, resulting in model elements with no traceable code.</p> <p data-bbox="385 1119 1335 1180">An exception to this rule is setting the Gain value to a named parameter data object with a nonauto storage class.</p>
Rationale	Support the generation of traceable code.

ID: Title	hisl_0066: Usage of Gain blocks
<p>Model Advisor Checks</p>	<ul style="list-style-type: none"> • By Task > Modeling Standards for DO-178C/DO-331 > High-Integrity Systems > Simulink > Check usage of Math Operation blocks • By Task > Modeling Standards for IEC 61508 > High-Integrity Systems > Simulink > Check usage of Math Operation blocks • By Task > Modeling Standards for IEC 62304 > High-Integrity Systems > Simulink > Check usage of Math Operation blocks • By Task > Modeling Standards for EN 50128 > High-Integrity Systems > Simulink > Check usage of Math Operation blocks • By Task > Modeling Standards for ISO 26262 > High-Integrity Systems > Simulink > Check usage of Math Operation blocks <p>For DO-178C/DO-331 check details, see Check usage of Math Operations blocks.</p> <p>For IEC 61508, IEC 62304, EN 50128, and ISO 26262 check details, see Check usage of Math Operations blocks.</p>
<p>References</p>	<ul style="list-style-type: none"> • DO-331, Section MB.6.3.2.d 'Low-level requirements are verifiable' • IEC 61508-3, Table A.3 (3) 'Language subset' • IEC 61508-3, Table A.4 (3) 'Defensive programming' • IEC 61508-3, Table B.8 (3) 'Control Flow Analysis' • IEC 62304, 5.5.3 - Software Unit acceptance criteria • ISO 26262-6, Table 1 (1b) 'Use of language subsets' • ISO 26262-6, Table 1 (1d) 'Use of defensive implementation techniques' • ISO 26262-6, Table 9 (f) 'Control flow analysis' • EN 50128, Table A.4 (11) 'Language Subset' • EN 50128, Table A.3 (1) 'Defensive Programming' • EN 50128, Table A.19 (3) 'Control Flow Analysis'
<p>Last Changed</p>	<p>R2018a</p>

Ports & Subsystems

In this section...
“hisl_0006: Usage of While Iterator blocks” on page 2-21
“hisl_0007: Usage of While Iterator subsystems” on page 2-23
“hisl_0008: Usage of For Iterator Blocks” on page 2-24
“hisl_0009: Usage of For Iterator Subsystem blocks” on page 2-26
“hisl_0010: Usage of If blocks and If Action Subsystem blocks” on page 2-27
“hisl_0011: Usage of Switch Case blocks and Action Subsystem blocks” on page 2-30
“hisl_0012: Usage of conditionally executed subsystems” on page 2-32
“hisl_0024: Inport interface definition” on page 2-33
“hisl_0025: Design min/max specification of input interfaces” on page 2-35
“hisl_0026: Design min/max specification of output interfaces” on page 2-37

hisl_0006: Usage of While Iterator blocks

ID: Title	hisl_0006: Usage of While Iterator blocks	
Description	To support bounded iterative behavior in the generated code when using the While Iterator block, in the While Iterator block parameters dialog box:	
	A	Set Maximum number of iterations to a positive integer value; do not set value to -1 for unlimited.
	B	Consider selecting Show iteration number port to observe the iteration value during simulation.
Note	When you use While Iterator subsystems, set the maximum number of iterations. If you use an unlimited number of iterations, the generated code might include infinite loops, which lead to execution-time overruns.	
	To observe the iteration value during simulation and determine whether the loop reaches the maximum number of iterations, select the While Iterator block parameter Show iteration number port . If the loop reaches the maximum number of iterations, verify the output values of the While Iterator block.	
Rationale	A, B	Support bounded iterative in the generated code.

ID: Title	hisl_0006: Usage of While Iterator blocks
Model Advisor Checks	<ul style="list-style-type: none"> • By Task > Modeling Standards for DO-178C/DO-331 > High-Integrity Systems > Simulink > Check usage of Ports and Subsystems blocks • By Task > Modeling Standards for IEC 61508 > High-Integrity Systems > Simulink > Check usage of Ports and Subsystems blocks • By Task > Modeling Standards for IEC 62304 > High-Integrity Systems > Simulink > Check usage of Ports and Subsystems blocks • By Task > Modeling Standards for ISO 26262 > High-Integrity Systems > Simulink > Check usage of Ports and Subsystems blocks • By Task > Modeling Standards for EN 50128 > High-Integrity Systems > Simulink > Check usage of Ports and Subsystems blocks <p>For DO-178C/DO-331 check details, see Check usage of Ports and Subsystems blocks.</p> <p>For IEC 61508, IEC 62304, EN 50128, and ISO 26262 check details, see Check usage of Ports and Subsystems blocks.</p>
References	<ul style="list-style-type: none"> • IEC 61508-3, Table A.3 (3) 'Language subset' • IEC 61508-3, Table A.4 (3) 'Defensive programming' • IEC 62304, 5.5.3 - Software Unit acceptance criteria • ISO 26262-6, Table 1 (1b) 'Use of language subsets' • ISO 26262-6, Table 1 (1d) 'Use of defensive implementation techniques' • EN 50128, Table A.4 (11) 'Language Subset' • EN 50128, Table A.3 (1) 'Defensive Programming' • DO-331, Section MB.6.3.1.e 'High-level requirements conform to standards' • DO-331, Section MB.6.3.2.e 'Low-level requirements conform to standards' • MISRA C:2012, Dir 4.1
Last Changed	R2016a

hisl_0007: Usage of While Iterator subsystems

ID: Title	hisl_0007: Usage of While Iterator subsystems
Description	To support unambiguous behavior, when using While Iterator subsystems, avoid using sample time-dependent blocks, such as integrators, filters, and transfer functions, within the subsystems.
Rationale	Avoid ambiguous behavior from the subsystem.
Model Advisor Checks	<ul style="list-style-type: none"> • By Task > Modeling Standards for DO-178C/DO-331 > High-Integrity Systems > Simulink > Check usage of Ports and Subsystems blocks • By Task > Modeling Standards for IEC 61508 > High-Integrity Systems > Simulink > Check usage of Ports and Subsystems blocks • By Task > Modeling Standards for IEC 62304 > High-Integrity Systems > Simulink > Check usage of Ports and Subsystems blocks • By Task > Modeling Standards for ISO 26262 > High-Integrity Systems > Simulink > Check usage of Ports and Subsystems blocks • By Task > Modeling Standards for EN 50128 > High-Integrity Systems > Simulink > Check usage of Ports and Subsystems blocks <p>For DO-178C/DO-331 check details, see Check usage of Ports and Subsystems blocks.</p> <p>For IEC 61508, IEC 62304, EN 50128, and ISO 26262 check details, see Check usage of Ports and Subsystems blocks.</p>
References	<ul style="list-style-type: none"> • IEC 61508-3, Table A.3 (3) 'Language subset' • IEC 61508-3, Table A.4 (3) 'Defensive programming' • IEC 62304, 5.5.3 - Software Unit acceptance criteria • ISO 26262-6, Table 1 (1b) 'Use of language subsets' • ISO 26262-6, Table 1 (1d) 'Use of defensive implementation techniques' • EN 50128, Table A.4 (11) 'Language Subset' • EN 50128, Table A.3 (1) 'Defensive Programming' • DO-331, Section MB.6.3.1.e 'High-level requirements conform to standards' • DO-331, Section MB.6.3.2.e 'Low-level requirements conform to standards'
Last Changed	R2016a

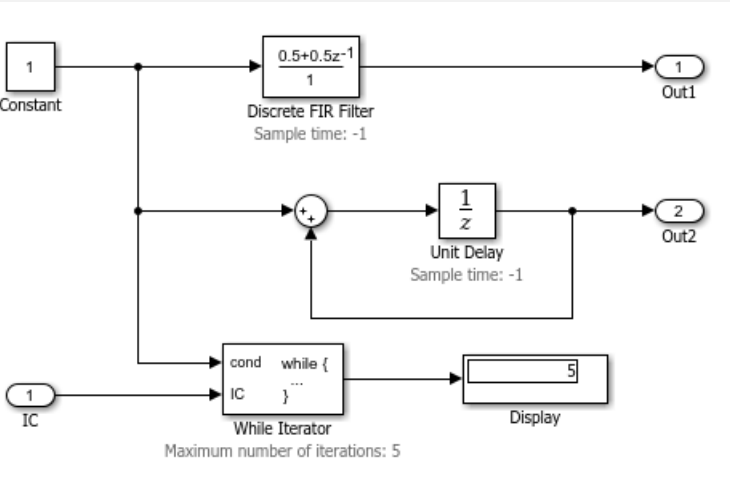
ID: Title	hisl_0007: Usage of While Iterator subsystems
Examples	<p>The following example causes a warning: the Discrete FIR Filter block is time-dependent and is in a For or While Iterator subsystem.</p>  <p>The diagram illustrates a Simulink model within a 'While Iterator' block. The 'While Iterator' block has a 'cond' field set to 'while { ... }' and an 'IC' field set to '1'. It contains three main components: <ul style="list-style-type: none"> A 'Constant' block with the value '1' that branches into two paths. A 'Discrete FIR Filter' block with the transfer function $\frac{0.5+0.5z^{-1}}{1}$ and a 'Sample time' of '-1'. It receives the signal from the 'Constant' block and outputs to 'Out1'. A 'Unit Delay' block with the transfer function $\frac{1}{z}$ and a 'Sample time' of '-1'. It receives the signal from the 'Constant' block and outputs to 'Out2'. A 'Display' block with the value '5'. It receives the signal from the 'While Iterator' block. The 'While Iterator' block also has a 'Maximum number of iterations' parameter set to '5'. </p>

hisl_0008: Usage of For Iterator Blocks

ID: Title	hisl_0008: Usage of For Iterator blocks								
Description	<p>To support bounded iterative behavior in the generated code when using the For Iterator block, do one of the following:</p> <table border="1" data-bbox="373 1128 1338 1458"> <tbody> <tr> <td data-bbox="373 1128 452 1206">A</td> <td data-bbox="458 1128 1338 1206">In the For Iterator block parameters dialog box, set Iteration limit source to <code>internal</code>.</td> </tr> <tr> <td data-bbox="373 1213 452 1291">B</td> <td data-bbox="458 1213 1338 1291">If Iteration limit source must be external, use a block that has a constant value, such as a Width, Probe, or Constant.</td> </tr> <tr> <td data-bbox="373 1298 452 1376">C</td> <td data-bbox="458 1298 1338 1376">In the For Iterator block parameters dialog box, clear Set next i (iteration variable) externally.</td> </tr> <tr> <td data-bbox="373 1383 452 1458">D</td> <td data-bbox="458 1383 1338 1458">In the For Iterator block parameters dialog box, consider selecting Show iteration variable to observe the iteration value during simulation.</td> </tr> </tbody> </table>	A	In the For Iterator block parameters dialog box, set Iteration limit source to <code>internal</code> .	B	If Iteration limit source must be external, use a block that has a constant value, such as a Width, Probe, or Constant.	C	In the For Iterator block parameters dialog box, clear Set next i (iteration variable) externally .	D	In the For Iterator block parameters dialog box, consider selecting Show iteration variable to observe the iteration value during simulation.
A	In the For Iterator block parameters dialog box, set Iteration limit source to <code>internal</code> .								
B	If Iteration limit source must be external, use a block that has a constant value, such as a Width, Probe, or Constant.								
C	In the For Iterator block parameters dialog box, clear Set next i (iteration variable) externally .								
D	In the For Iterator block parameters dialog box, consider selecting Show iteration variable to observe the iteration value during simulation.								

ID: Title	hisl_0008: Usage of For Iterator blocks	
Notes	When you use the For Iterator block, feed the loop control variable with fixed (nonvariable) values to get a predictable number of loop iterations. Otherwise, a loop can result in unpredictable execution times and, in the case of external iteration variables, infinite loops that can lead to execution-time overruns.	
Rationale	A, B, C, D	Support bounded iterative behavior in generated code.
Model Advisor Checks	<ul style="list-style-type: none"> • By Task > Modeling Standards for DO-178C/DO-331 > High-Integrity Systems > Simulink > Check usage of Ports and Subsystems blocks • By Task > Modeling Standards for IEC 61508 > High-Integrity Systems > Simulink > Check usage of Ports and Subsystems blocks • By Task > Modeling Standards for IEC 62304 > High-Integrity Systems > Simulink > Check usage of Ports and Subsystems blocks • By Task > Modeling Standards for ISO 26262 > High-Integrity Systems > Simulink > Check usage of Ports and Subsystems blocks • By Task > Modeling Standards for EN 50128 > High-Integrity Systems > Simulink > Check usage of Ports and Subsystems blocks <p>For DO-178C/DO-331 check details, see Check usage of Ports and Subsystems blocks.</p> <p>For IEC 61508, IEC 62304, EN 50128, and ISO 26262 check details, see Check usage of Ports and Subsystems blocks.</p>	
References	<ul style="list-style-type: none"> • IEC 61508-3, Table A.3 (3) 'Language subset' • IEC 61508-3, Table A.4 (3) 'Defensive programming' • IEC 62304, 5.5.3 - Software Unit acceptance criteria • ISO 26262-6, Table 1 (1b) 'Use of language subsets' • ISO 26262-6, Table 1 (1d) 'Use of defensive implementation techniques' • EN 50128, Table A.4 (11) 'Language Subset' • EN 50128, Table A.3 (1) 'Defensive Programming' • DO-331, MB.Section 6.3.1.e 'High-level requirements conform to standards' • DO-331, Section MB.6.3.2.e 'Low-level requirements conform to standards' • MISRA C:2012, Rule 14.2 	

ID: Title	hisl_0008: Usage of For Iterator blocks
Last Changed	R2016a

hisl_0009: Usage of For Iterator Subsystem blocks

ID: Title	hisl_0009: Usage of For Iterator Subsystem blocks
Description	To support unambiguous behavior when using the For Iterator Subsystem block, avoid using sample time-dependent blocks such as integrators, filters, and transfer functions within the subsystem.
Rationale	Avoid ambiguous behavior from the subsystem.
Model Advisor Checks	<ul style="list-style-type: none"> • By Task > Modeling Standards for DO-178C/DO-331 > High-Integrity Systems > Simulink > Check usage of Ports and Subsystems blocks • By Task > Modeling Standards for IEC 61508 > High-Integrity Systems > Simulink > Check usage of Ports and Subsystems blocks • By Task > Modeling Standards for IEC 62304 > High-Integrity Systems > Simulink > Check usage of Ports and Subsystems blocks • By Task > Modeling Standards for ISO 26262 > High-Integrity Systems > Simulink > Check usage of Ports and Subsystems blocks • By Task > Modeling Standards for EN 50128 > High-Integrity Systems > Simulink > Check usage of Ports and Subsystems blocks <p>For DO-178C/DO-331 check details, see Check usage of Ports and Subsystems blocks.</p> <p>For IEC 61508, IEC 62304, EN 50128, and ISO 26262 check details, see Check usage of Ports and Subsystems blocks.</p>

ID: Title	hisl_0009: Usage of For Iterator Subsystem blocks
References	<ul style="list-style-type: none"> IEC 61508-3, Table A.3 (3) 'Language subset' IEC 61508-3, Table A.4 (3) 'Defensive programming' IEC 62304, 5.5.3 - Software Unit acceptance criteria ISO 26262-6, Table 1 (1b) 'Use of language subsets' ISO 26262-6, Table 1 (1d) 'Use of defensive implementation techniques' EN 50128, Table A.4 (11) 'Language Subset' EN 50128, Table A.3 (1) 'Defensive Programming' DO-331, Sections MB.6.3.1.g and MB.6.3.2.g 'Algorithms are accurate'
Last Changed	R2016b
Examples	See "hisl_0007: Usage of While Iterator subsystems" on page 2-23.

hisl_0010: Usage of If blocks and If Action Subsystem blocks

ID: Title	hisl_0010: Usage of If blocks and If Action Subsystem blocks
Description	To support verifiable generated code, when using the If block with nonempty <code>Elseif</code> expressions,
	A In the block parameter dialog box, select Show else condition .
	B Connect the outports of the If block to If Action Subsystem blocks.
Prerequisites	"hisl_0016: Usage of blocks that compute relational operators" on page 2-50
Notes	The combination of If and If Action Subsystem blocks enable conditional execution based on input conditions. When there is only an <code>if</code> branch, you do not need to include an <code>else</code> branch.
Rationale	A, B Support generation of verifiable code.

ID: Title	hisl_0010: Usage of If blocks and If Action Subsystem blocks
Model Advisor Checks	<ul style="list-style-type: none"> • By Task > Modeling Standards for DO-178C/DO-331 > High-Integrity Systems > Simulink > Check usage of Ports and Subsystems blocks • By Task > Modeling Standards for IEC 61508 > High-Integrity Systems > Simulink > Check usage of Ports and Subsystems blocks • By Task > Modeling Standards for IEC 62304 > High-Integrity Systems > Simulink > Check usage of Ports and Subsystems blocks • By Task > Modeling Standards for ISO 26262 > High-Integrity Systems > Simulink > Check usage of Ports and Subsystems blocks • By Task > Modeling Standards for EN 50128 > High-Integrity Systems > Simulink > Check usage of Ports and Subsystems blocks <p>For DO-178C/DO-331 check details, see Check usage of Ports and Subsystems blocks.</p> <p>For IEC 61508, IEC 62304, EN 50128, and ISO 26262 check details, see Check usage of Ports and Subsystems blocks.</p>
References	<ul style="list-style-type: none"> • IEC 61508-3, Table A.3 (3) 'Language subset' • IEC 61508-3, Table A.4 (3) 'Defensive programming' • IEC 62304, 5.5.3 - Software Unit acceptance criteria • ISO 26262-6, Table 1(b) 'Use of language subsets' • ISO 26262-6, Table 1(d) 'Use of defensive implementation techniques' • EN 50128, Table A.4 (11) 'Language Subset' • EN 50128, Table A.3 (1) 'Defensive Programming' • DO-331, Sections MB.6.3.1.g and MB.6.3.2.g 'Algorithms are accurate' • DO-331 Section MB.6.3.1.b - High-level requirements are accurate and consistent • DO-331 Section MB.6.3.2.b - Low-level requirements are accurate and consistent
See Also	na_0012: Use of Switch vs. If-Then-Else Action Subsystem in the Simulink documentation
Last Changed	R2016b

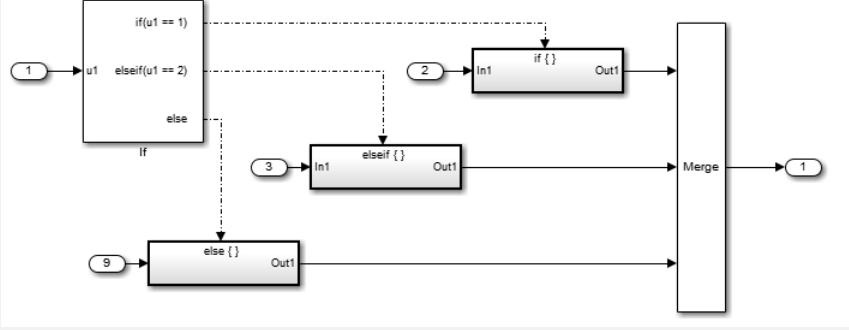
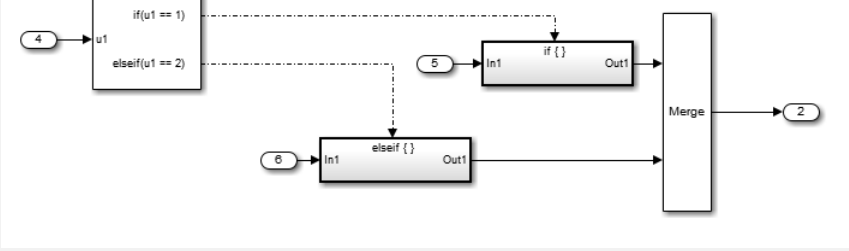
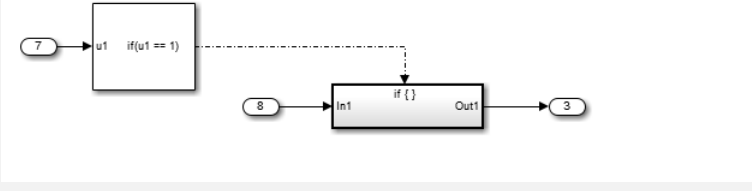
ID: Title	hisl_0010: Usage of If blocks and If Action Subsystem blocks
Examples	 <p>Recommended: Elseif with Else</p>
	 <p>Not Recommended: No Else Path</p>
	 <p>Recommended: Only an If, no Else required</p>

hisl_0011: Usage of Switch Case blocks and Action Subsystem blocks

ID: Title	hisl_0011: Usage of Switch Case blocks and Action Subsystem blocks	
Description	To support verifiable generated code, when using the Switch Case block:	
	A	In the Switch Case block parameter dialog box, select Show default case .
	B	Connect the outports of the Switch Case block to a Switch Case Action Subsystem block.
	C	Use an integer data type or an enumeration value for the inputs to Switch Case blocks.
Prerequisites	"hisl_0016: Usage of blocks that compute relational operators" on page 2-50	
Notes	The combination of Switch Case and If Action Subsystem blocks enable conditional execution based on input conditions. Provide a default path of execution in the form of a "Default" block.	
Rationale	A, B, C	Support generation of verifiable code.
Model Advisor Checks	<ul style="list-style-type: none"> • By Task > Modeling Standards for DO-178C/DO-331 > High-Integrity Systems > Simulink > Check usage of Ports and Subsystems blocks • By Task > Modeling Standards for IEC 61508 > High-Integrity Systems > Simulink > Check usage of Ports and Subsystems blocks • By Task > Modeling Standards for IEC 62304 > High-Integrity Systems > Simulink > Check usage of Ports and Subsystems blocks • By Task > Modeling Standards for ISO 26262 > High-Integrity Systems > Simulink > Check usage of Ports and Subsystems blocks • By Task > Modeling Standards for EN 50128 > High-Integrity Systems > Simulink > Check usage of Ports and Subsystems blocks <p>For DO-178C/DO-331 check details, see Check usage of Ports and Subsystems blocks.</p> <p>For IEC 61508, IEC 62304, EN 50128, and ISO 26262 check details, see Check usage of Ports and Subsystems blocks.</p>	

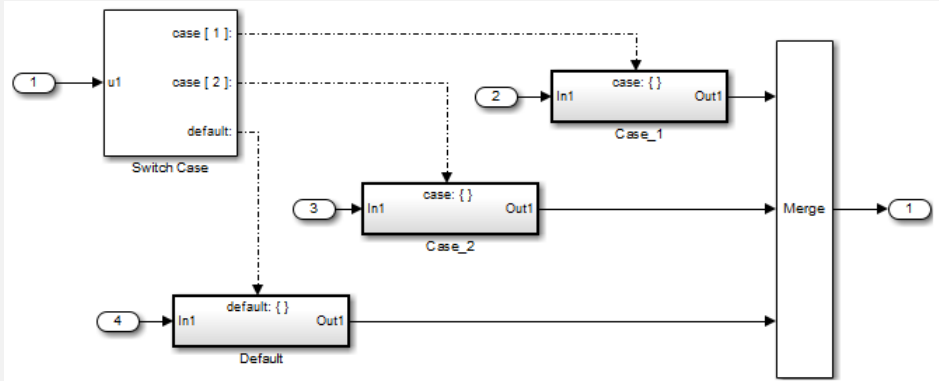
ID: Title	hisl_0011: Usage of Switch Case blocks and Action Subsystem blocks
References	<ul style="list-style-type: none"> • IEC 61508-3, Table A.3 (3) 'Language subset' • IEC 61508-3, Table A.4 (3) 'Defensive programming' • IEC 62304, 5.5.3 - Software Unit acceptance criteria • ISO 26262-6, Table 1(b) 'Use of language subsets' • ISO 26262-6, Table 1(d) 'Use of defensive implementation techniques' • EN 50128, Table A.4 (11) 'Language Subset' • EN 50128, Table A.3 (1) 'Defensive Programming' • MISRA C:2012, Rule 16.4 • DO-331, Sections MB.6.3.1.g and MB.6.3.2.g 'Algorithms are accurate' • DO-331 Section MB.6.3.1.b - High-level requirements are accurate and consistent • DO-331 Section MB.6.3.2.b - Low-level requirements are accurate and consistent
See Also	db_0115: Simulink patterns for case constructs in the Simulink documentation.
Last Changed	R2016b
Examples	<p>The following graphic displays an example of providing a default path of execution using a “Default” block.</p>  <p>The diagram illustrates a Simulink model for handling multiple cases. It starts with a 'Switch Case' block that receives three inputs: 'case [1]', 'case [2]', and 'default:'. These inputs are connected via dashed lines to three corresponding case blocks: 'Case_1', 'Case_2', and 'Default'. Each case block has an 'In1' input and an 'Out1' output. 'Case_1' and 'Case_2' have an input labeled 'case: {}'. The outputs of all three case blocks are connected to a 'Merge' block. The output of the 'Merge' block is labeled '1'.</p>

hisl_0012: Usage of conditionally executed subsystems

ID: Title	hisl_0012: Usage of conditionally executed subsystems	
Description	To support unambiguous behavior, when using conditionally executed subsystems:	
	A	Specify inherited (-1) sample times for all blocks in the subsystem, except Constant. Constant blocks can use infinite (<code>inf</code>) sample time.
	B	If the subsystem is called asynchronously, avoid using sample time-dependent blocks, such as integrators, filters, and transfer functions, within the subsystem.
Notes	<p>Conditionally executed subsystems include:</p> <ul style="list-style-type: none"> • If Action • Switch Case Action • Function-Call • Triggered • Enabled <p>Sample time-dependent blocks include:</p> <ul style="list-style-type: none"> • Discrete State-Space • Discrete-Time Integrator • Discrete FIR Filter • Discrete Filter • Discrete Transfer Fcn • Discrete Zero-Pole • Transfer Fcn First Order • Transfer Fcn Real Zero • Transfer Fcn Lead or Lag 	
Rationale	A, B	Support unambiguous behavior.

ID: Title	hisl_0012: Usage of conditionally executed subsystems
References	<ul style="list-style-type: none"> • IEC 61508-3, Table A.3 (3) 'Language subset' • IEC 61508-3, Table A.4 (3) 'Defensive programming' • IEC 62304, 5.5.3 - Software Unit acceptance criteria • ISO 26262-6, Table 1(b) 'Use of language subsets' • ISO 26262-6, Table 1(d) 'Use of defensive implementation techniques' • EN 50128, Table A.4 (11) 'Language Subset' • EN 50128, Table A.3 (1) 'Defensive Programming' • DO-331, Sections MB.6.3.1.g and MB.6.3.2.g 'Algorithms are accurate'
Last Changed	R2016b
Examples	When using discrete blocks, the behavior depends on the operation across multiple contiguous time steps. When the blocks are called intermittently, the results may not conform to your expectations.

hisl_0024: Inport interface definition

ID: Title	hisl_0024: Inport interface definition
Description	<p>To support strong data typing and unambiguous behavior of the model and the generated code, for each root-level Inport block or Simulink signal object that explicitly resolves to the connected signal line, set the following parameters:</p> <ul style="list-style-type: none"> • Data type • Port dimensions • Sample time
Note	Using root-level Inport blocks without fully defined dimensions, sample times, or data type can lead to ambiguous simulation results. If you do not explicitly define these parameters, Simulink back-propagates dimensions, sample times, and data types from downstream blocks.
Rationale	<ul style="list-style-type: none"> • Avoid unambiguous behavior. • Support full specification of software interface.

ID: Title	hisl_0024: Inport interface definition
Model Advisor Checks	<ul style="list-style-type: none"> • By Task > Modeling Standards for DO-178C/DO-331 > High-Integrity Systems > Simulink > Check for root Inports with missing properties • By Task > Modeling Standards for IEC 61508 > High-Integrity Systems > Simulink > Check for root Inports with missing properties • By Task > Modeling Standards for IEC 62304 > High-Integrity Systems > Simulink > Check for root Inports with missing properties • By Task > Modeling Standards for ISO 26262 > High-Integrity Systems > Simulink > Check for root Inports with missing properties • By Task > Modeling Standards for EN 50128 > High-Integrity Systems > Simulink > Check for root Inports with missing properties <p>For DO-178C/DO-331 check details, see Check for root Inports with missing properties.</p> <p>For IEC 61508, IEC 62304, EN 50128, and ISO 26262 check details, see Check for root Inports with missing properties.</p>
References	<ul style="list-style-type: none"> • DO-331 Section MB.6.3.1.b 'High-level requirements are accurate and consistent' • DO-331 Section MB.6.3.2.b 'Low-level requirements are accurate and consistent' • IEC 61508-3, Table B.9 (6) 'Fully defined interface' • IEC 62304, 5.5.3 - Software Unit acceptance criteria • ISO 26262-4, Table 2 (2) 'Precisely defined interfaces' • EN 50128, Table A.3 (19) 'Fully Defined Interface'
Last Changed	R2017b

hisl_0025: Design min/max specification of input interfaces

ID: Title	hisl_0025: Design min/max specification of input interfaces
Description	Provide design min/max information for root-level Inport blocks to specify the input interface ranges.
Notes	<ul style="list-style-type: none"> • Specifying the range of Inport blocks on the root level enables additional capabilities^a. Examples include: <ul style="list-style-type: none"> • Detection of overflows through simulation range checking. • Code optimizations using Embedded Coder. • Design model verification using Simulink Design Verifier™. • Fixed-point autoscaling using Fixed-Point Designer™. • Specified design ranges can be used by Embedded Coder to optimize the generated code. If you want to use design ranges for optimization, in the Configuration Parameters dialog box, on the Code Generation pane, consider selecting Optimize using the specified minimum and maximum values. • Ranges for bus-type Inport blocks are specified with the bus elements of the defining bus object. Simulink ignores range specifications provided directly at Inport blocks that are bus-type.
Rationale	Support precise specification of the input interface.

ID: Title	hisl_0025: Design min/max specification of input interfaces
Model Advisor Checks	<ul style="list-style-type: none"> • By Task > Modeling Standards for DO-178C/DO-331 > High-Integrity Systems > Simulink > Check for root Inports with missing range definitions • By Task > Modeling Standards for IEC 61508 > High-Integrity Systems > Simulink > Check for root Inports with missing range definitions • By Task > Modeling Standards for IEC 62304 > High-Integrity Systems > Simulink > Check for root Inports with missing range definitions • By Task > Modeling Standards for ISO 26262 > High-Integrity Systems > Simulink > Check for root Inports with missing range definitions • By Task > Modeling Standards for EN 50128 > High-Integrity Systems > Simulink > Check for root Inports with missing range definitions <p>For DO-178C/DO-331 check details, see Check for root Inports with missing range definitions.</p> <p>For IEC 61508, IEC 62304, EN 50128, and ISO 26262 check details, see Check for root Inports with missing range definitions.</p>
References	<ul style="list-style-type: none"> • DO-331 Section MB.6.3.1.b 'High-level requirements are accurate and consistent' • DO-331 Section MB.6.3.2.b 'Low-level requirements are accurate and consistent' • IEC 61508-3, Table B.9 (6) 'Fully defined interface' • IEC 62304, 5.5.3 - Software Unit acceptance criteria • ISO 26262-4, Table 2 (2) 'Precisely defined interfaces' • EN 50128, Table A.1(11) - Software Interface Specifications • EN 50128 Table A.3 (19) 'Fully Defined Interface'
Last Changed	R2017b

a. These capabilities leverage design range information for different purposes. For more information, refer to the documentation for the tools you intend to use.

hisl_0026: Design min/max specification of output interfaces

ID: Title	hisl_0026: Design min/max specification of output interfaces
Description	Provide design min/max information for root-level Outport blocks to specify the output interface ranges.
Notes	<ul style="list-style-type: none"> • Specifying the range of Outport blocks on the root level enables additional capabilities^a. Examples include: <ul style="list-style-type: none"> • Detection of overflows through simulation range checking. • Code optimizations using Embedded Coder. • Design model verification using Simulink Design Verifier. • Fixed-point autoscaling using Fixed-Point Designer. • Specified design ranges can be used by Embedded Coder to optimize the generated code. If you want to use design ranges for optimization, in the Configuration Parameters dialog box, on the Code Generation pane, consider selecting Optimize using the specified minimum and maximum values. • Ranges for bus-type Outport blocks are specified with the bus elements of the defining bus object. Simulink ignores range specifications provided directly at Outport blocks that are bus-type.
Rationale	Support precise specification of the output interface.

ID: Title	hisl_0026: Design min/max specification of output interfaces
Model Advisor Checks	<ul style="list-style-type: none"> • By Task > Modeling Standards for DO-178C/DO-331 > High-Integrity Systems > Simulink > Check for root Outports with missing range definitions • By Task > Modeling Standards for IEC 61508 > High-Integrity Systems > Simulink > Check for root Outports with missing range definitions • By Task > Modeling Standards for IEC 62304 > High-Integrity Systems > Simulink > Check for root Outports with missing range definitions • By Task > Modeling Standards for ISO 26262 > High-Integrity Systems > Simulink > Check for root Outports with missing range definitions • By Task > Modeling Standards for EN 50128 > High-Integrity Systems > Simulink > Check for root Outports with missing range definitions <p>For DO-178C/DO-331 check details, see Check for root Outports with missing range definitions.</p> <p>For IEC 61508, IEC 62304, EN 50128, and ISO 26262 check details, see Check for root Outports with missing range definitions.</p>
References	<ul style="list-style-type: none"> • DO-331 Section MB.6.3.1.b 'High-level requirements are accurate and consistent' • DO-331 Section MB.6.3.2.b 'Low-level requirements are accurate and consistent' • IEC 61508-3, Table B.9 (6) 'Fully defined interface' • IEC 62304, 5.5.3 - Software Unit acceptance criteria • ISO 26262-4, Table 2 (2) 'Precisely defined interfaces' • EN 50128, Table A.1(11) - Software Interface Specifications • EN 50128 Table A.3 (19) 'Fully Defined Interface'
Last Changed	R2017b

a. These capabilities leverage design range information for different purposes. For more information, refer to the documentation for the tools you intend to use.

Signal Routing

In this section...

- “hisl_0013: Usage of data store blocks” on page 2-39
- “hisl_0015: Usage of Merge blocks” on page 2-43
- “hisl_0021: Consistent vector indexing method” on page 2-45
- “hisl_0022: Data type selection for index signals” on page 2-46
- “hisl_0023: Verification of model and subsystem variants” on page 2-47
- “hisl_0034: Usage of Signal Routing blocks” on page 2-48

hisl_0013: Usage of data store blocks

ID: Title	hisl_0013: Usage of data store blocks	
Description	To support deterministic behavior across different sample times or models when using data store blocks, including Data Store Memory, Data Store Read, and Data Store Write:	
	A	In the Configuration Parameters dialog box, on the Diagnostics > Data Validity pane, under Data Store Memory block , set the following parameters to error: <ul style="list-style-type: none"> • Detect read before write • Detect write after read • Detect write after write • Multitask data store • Duplicate data store names
	B	Avoid data store reads and writes that occur across model and atomic subsystem boundaries.
	C	Avoid using data stores to write and read data at different rates, because different rates can result in inconsistent exchanges of data. To provide deterministic data coupling in multirate systems, use Rate Transition blocks before Data Store Write blocks, or after Data Store Read blocks.

ID: Title	hisl_0013: Usage of data store blocks	
Notes	<p>The sorting algorithm in Simulink does not take into account data coupling between models and atomic subsystems.</p> <p>Using data store memory blocks can have significant impact on your software verification effort. Models and subsystems that use only inports and outports to pass data provide a directly traceable interface, simplifying the verification process.</p>	
Rationale	A, B, C	Support consistent data values across different sample times or models.
Model Advisor Checks	<ul style="list-style-type: none"> • By Task > Modeling Standards for DO-178C/DO-331 > High-Integrity Systems > Configuration > Check safety-related diagnostic settings for data store memory • By Task > Modeling Standards for IEC 61508 > High-Integrity Systems > Configuration > Check safety-related diagnostic settings for data store memory • By Task > Modeling Standards for IEC 62304 > High-Integrity Systems > Configuration > Configuration > Check safety-related diagnostic settings for data store memory • By Task > Modeling Standards for ISO 26262 > High-Integrity Systems > Configuration > Configuration > Check safety-related diagnostic settings for data store memory • By Task > Modeling Standards for EN 50128 > High-Integrity Systems > Configuration > Configuration > Check safety-related diagnostic settings for data store memory <p>For DO-178C/DO-331 check details, see Check safety-related diagnostic settings for data store memory.</p> <p>For IEC 61508, IEC 62304, EN 50128, and ISO 26262 check details, see Check safety-related diagnostic settings for data store memory.</p>	

ID: Title	hisl_0013: Usage of data store blocks
References	<ul style="list-style-type: none">• IEC 61508-3, Table A.3 (3) 'Language subset'• IEC 61508-3, Table A.4 (3) 'Defensive programming'• IEC 62304, 5.5.3 - Software Unit acceptance criteria• ISO 26262-6, Table 1 (1b) 'Use of language subsets'• ISO 26262-6, Table 1 (1d) 'Use of defensive implementation techniques'• EN 50128, Table A.4 (11) 'Language Subset'• EN 50128, Table A.3 (1) 'Defensive Programming'• DO-331, Section MB.6.3.3.b 'Software architecture is consistent'
Last Changed	R2017b

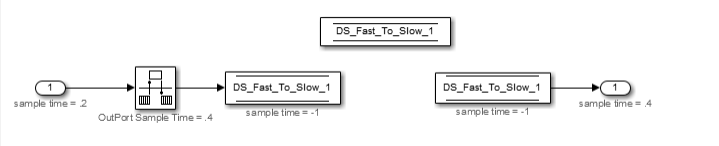
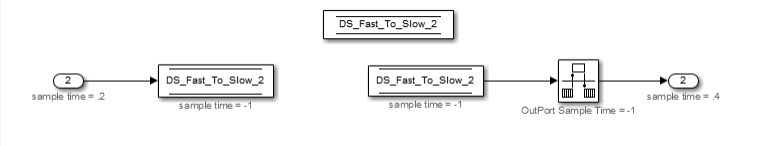
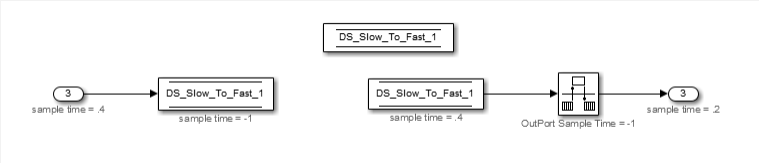
ID: Title	hisl_0013: Usage of data store blocks
Examples	<p>The following examples use Rate Transition blocks to provide deterministic data coupling in multirate systems</p> <ul style="list-style-type: none"> For fast-to-slow transitions: <p>Set the rate of the slow sample time on either the Rate Transition block or the Data Store Write block.</p>  <p>Do not place the Rate Transition block after the Data Store Read block.</p>  For slow-to-fast transitions: <p>If the Rate Transition block is after the Data Store Read block, specify the slow rate on the Data Store Read block.</p>  <p>If the Rate Transition block is before the Data Store Write block, use the inherited sample time for the blocks.</p>

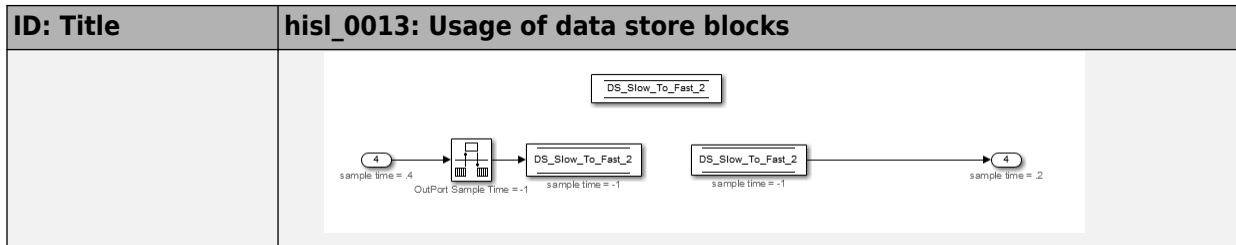

hisl_0015: Usage of Merge blocks

ID: Title	hisl_0015: Usage of Merge blocks	
Description	To support unambiguous behavior from Merge blocks,	
Notes	A	Use Merge blocks only with conditionally executed subsystems.
	B	Specify execution of the conditionally executed subsystems such that only one subsystem executes during a time step.
	C	Clear the Merge block parameter Allow unequal port widths .
Prerequisites	hisl_0303: Configuration Parameters > Diagnostics > Merge block hisl_0304: Configuration Parameters > Diagnostics > Model initialization	
Rationale	A, B, C	Avoid unambiguous behavior.

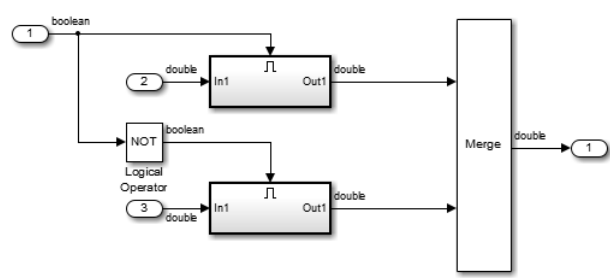
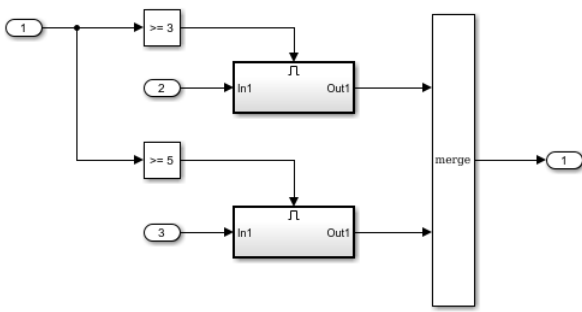
ID: Title	hisl_0015: Usage of Merge blocks
References	<ul style="list-style-type: none"> • IEC 61508-3, Table A.3 (3) 'Language subset' • IEC 61508-3, Table A.4 (3) 'Defensive programming' • IEC 62304, 5.5.3 - Software Unit acceptance criteria • ISO 26262-6, Table 1(b) 'Use of language subsets' • ISO 26262-6, Table 1(d) 'Use of defensive implementation techniques' • EN 50128, Table A.4 (11) 'Language Subset' • EN 50128, Table A.3 (1) 'Defensive Programming' • DO-331, Section MB.6.3.3.b 'Software architecture is consistent'
Last Changed	R2018a
Examples	<div data-bbox="372 654 1132 1012" style="border: 1px solid black; padding: 10px; margin-bottom: 10px;"> <p style="text-align: center;">Recommended</p>  <p>The diagram shows a 'Merge' block with two inputs. The top input is the output of an AND gate (labeled with the Greek letter pi) that takes a 'boolean' input (1) and a 'double' input (2). The bottom input is the output of another AND gate that takes the same 'boolean' input (1) and a 'double' input (3) that has first passed through a 'NOT Logical Operator' block.</p> </div> <div data-bbox="372 1041 1335 1515" style="border: 1px solid black; padding: 10px;"> <p style="text-align: center;">Recommended</p> <hr/> <p style="text-align: center;">Not Recommended</p>  <p>The diagram shows a 'merge' block with two inputs. The top input is the output of an AND gate (labeled with the Greek letter pi) that takes a 'double' input (2) and the output of a '>= 3' comparison block. The bottom input is the output of another AND gate that takes a 'double' input (3) and the output of a '>= 5' comparison block. Both comparison blocks receive a 'boolean' input (1).</p> <p style="text-align: center;">Not Recommended</p> </div>

hisl_0021: Consistent vector indexing method

ID: Title	hisl_0021: Consistent vector indexing method	
Description	Within a model, use:	
	A	<p>A consistent vector indexing method for all blocks. Blocks for which you should set the indexing method include:</p> <ul style="list-style-type: none"> • Index Vector • Multiport Switch • Assignment • Selector • For Iterator
Rationale	A	Reduce the risk of introducing errors due to inconsistent indexing.
Model Advisor Checks	<ul style="list-style-type: none"> • By Task > Modeling Standards for DO-178C/DO-331 > High-Integrity Systems > Simulink > Check for inconsistent vector indexing methods • By Task > Modeling Standards for IEC 61508 > High-Integrity Systems > Simulink > Check for inconsistent vector indexing methods • By Task > Modeling Standards for IEC 62304 > High-Integrity Systems > Simulink > Check for inconsistent vector indexing methods • By Task > Modeling Standards for ISO 26262 > High-Integrity Systems > Simulink > Check for inconsistent vector indexing methods • By Task > Modeling Standards for EN 50128 > High-Integrity Systems > Simulink > Check for inconsistent vector indexing methods <p>For DO-178C/DO-331 check details, see Check for inconsistent vector indexing methods.</p> <p>For IEC 61508, IEC 62304, EN 50128, and ISO 26262 check details, see Check for inconsistent vector indexing methods.</p>	

ID: Title	hisl_0021: Consistent vector indexing method
References	<ul style="list-style-type: none"> • IEC 61508-3, Table A.3 (3) 'Language subset' • IEC 61508-3, Table A.4 (5) 'Design and coding standards' • IEC 62304, 5.5.3 - Software Unit acceptance criteria • ISO 26262-6, Table 1 (1b) 'Use of language subsets' • ISO 26262-6, Table 1 (1e) 'Use of established design principles' • ISO 26262-6, Table 1 (1f) 'Use of unambiguous graphical representation' • ISO 26262-6, Table 1 (1g) 'Use of style guide' • ISO 26262-6, Table 1 (1h) 'Use of naming conventions' • EN 50128, Table A.4 (11) 'Language Subset' • EN 50128, Table A.12 (1) 'Coding Standard' • DO-331, Section MB.6.3.2.b 'Low-level requirements are accurate and consistent'
See Also	"cgsl_0101: Zero-based indexing"
Last Changed	R2016a

hisl_0022: Data type selection for index signals

ID: Title	hisl_0022: Data type selection for index signals	
Description	For index signals, use:	
	A	An integer or enumerated data type
	B	A data type that covers the range of indexed values.
	Blocks that use a signal index include: <ul style="list-style-type: none"> • Assignment • Direct Lookup Table (n-D) • Index Vector • Interpolation Using Prelookup • MATLAB® Function • Multiport Switch • Selector • Stateflow® Chart 	

ID: Title	hisl_0022: Data type selection for index signals	
Rationale	A	Prevent unexpected results that can occur with rounding operations for floating-point data types.
	B	Enable access to data in a vector.
References	<ul style="list-style-type: none"> • IEC 61508-3, Table A.3 (2) 'Strongly typed programming language' • IEC 61508-3, Table A.4 (3) 'Defensive programming' • IEC 62304, 5.5.3 - Software Unit acceptance criteria • ISO 26262-6, Table 1 (1b) 'Use of language subsets' • ISO 26262-6, Table 1 (1c) 'Enforcement of strong typing' • ISO 26262-6, Table 1 (1d) 'Use of defensive implementation techniques' • EN 50128, Table A.4 (8) 'Strongly Typed Programming Language' • EN 50128, Table A.3 (1) 'Defensive Programming' • DO-331, Section MB.6.3.4.f 'Accuracy and Consistency of Source Code' 	
Last Changed	R2017b	

hisl_0023: Verification of model and subsystem variants

ID: Title	hisl_0023: Verification of model and subsystem variants	
Description	When verifying that a model is consistent with generated code, do the following:	
	A	For each Model Variant block, verify that block parameter Generate preprocessor conditionals is cleared.
	B	For each Variant Subsystem block, verify that block parameter Analyze all choices during update diagram and generate preprocessor conditionals is cleared.
	C	Verify all combinations of model variants that might be active in the generated code.
Rationale	A,B	Simplify consistency testing between the model and generated code by restricting the code base to a single variant.
	C	Make sure that consistency testing between the model and generated code is complete for all variants.

ID: Title	hisl_0023: Verification of model and subsystem variants
Model Advisor Checks	<ul style="list-style-type: none"> • By Task > Modeling Standards for DO-178C/DO-331 > High-Integrity Systems > Simulink > Check for variant blocks with 'Generate preprocessor conditionals' active • By Task > Modeling Standards for IEC 61508 > High-Integrity Systems > Simulink > Check for variant blocks with 'Generate preprocessor conditionals' active • By Task > Modeling Standards for IEC 62304 > High-Integrity Systems > Simulink > Check for variant blocks with 'Generate preprocessor conditionals' active • By Task > Modeling Standards for EN 50128 > High-Integrity Systems > Simulink > Check for variant blocks with 'Generate preprocessor conditionals' active • By Task > Modeling Standards for ISO 26262 > High-Integrity Systems > Simulink > Check for variant blocks with 'Generate preprocessor conditionals' active <p>For DO-178C/DO-331 check details, see Check for variant blocks with 'Generate preprocessor conditionals' active.</p> <p>For IEC 61508, IEC 62304, EN 50128, and ISO 26262 check details, see Check for variant blocks with 'Generate preprocessor conditionals' active.</p>
References	<ul style="list-style-type: none"> • DO-331, Section MB.6.3.2.b 'Low-level requirements are accurate and consistent' • IEC 61508-3, Table A.4 (7) 'Use of trusted / verified software modules and components'
Last Changed	R2017b

hisl_0034: Usage of Signal Routing blocks

ID: Title	hisl_0034: Usage of Signal Routing blocks	
Description	To support the robustness of the operations when using Switch blocks:	
	A	Avoid comparisons using the ~= operator on floating-point data types.

ID: Title	hisl_0034: Usage of Signal Routing blocks	
Note	<p>Due to floating-point precision issues, do not test floating-point expressions for inequality (~=).</p> <p>When the model contains a Switch block computing a relational operator with the ~= operator, the inputs to the block must not be single, double, or any custom storage class that is a floating-point type. Change the data type of the input signals, or rework the model to eliminate using the ~= operator within Switch blocks.</p>	
Rationale	A	Improve model robustness.
Model Advisor Checks	<ul style="list-style-type: none"> • By Task > Modeling Standards for DO-178C/DO-331 > High-Integrity Systems > Simulink > Check usage of Signal Routing blocks • By Task > Modeling Standards for IEC 61508 > High-Integrity Systems > Simulink > Check usage of Signal Routing blocks • By Task > Modeling Standards for IEC 62304 > High-Integrity Systems > Simulink > Check usage of Signal Routing blocks • By Task > Modeling Standards for EN 50128 > High-Integrity Systems > Simulink > Check usage of Signal Routing blocks • By Task > Modeling Standards for ISO 26262 > High-Integrity Systems > Simulink > Check usage of Signal Routing blocks <p>For DO-178C/DO-331 check details, see Check usage of Signal Routing blocks.</p> <p>For IEC 61508, IEC 62304, EN 50128, and ISO 26262 check details, see Check usage of Signal Routing blocks.</p>	
References	<ul style="list-style-type: none"> • DO-331, Sections MB.6.3.1.g and MB.6.3.2.g 'Algorithms are accurate' • MISRA C:2012, Dir 1.1 	
Last Changed	R2017b	

Logic and Bit Operations

In this section...
“hisl_0016: Usage of blocks that compute relational operators” on page 2-50
“hisl_0017: Usage of blocks that compute relational operators (2)” on page 2-52
“hisl_0018: Usage of Logical Operator block” on page 2-54
“hisl_0019: Usage of Bitwise Operator block” on page 2-55

hisl_0016: Usage of blocks that compute relational operators

ID: Title	hisl_0016: Usage of blocks that compute relational operators	
Description	To support the robustness of the operations, when using blocks that compute relational operators, including Relational Operator, Compare To Constant, Compare To Zero, Detect Change, and If blocks:	
	A	Avoid comparisons using the == or ~= operator on floating-point data types.
Notes	Due to floating-point precision issues, do not test floating-point expressions for equality (==) or inequality (~=).	
	When the model contains a block computing a relational operator with the == or ~= operators, the inputs to the block must not be single, double, or any custom storage class that is a floating-point type. Change the data type of the input signals, or rework the model to eliminate using the == or ~= operators within blocks that compute relational operators.	
Rationale	A	Improve model robustness.

ID: Title	hisl_0016: Usage of blocks that compute relational operators
<p>Model Advisor Checks</p>	<ul style="list-style-type: none"> • By Task > Modeling Standards for DO-178C/DO-331 > High-Integrity Systems > Simulink > Check usage of Logic and Bit Operations blocks • By Task > Modeling Standards for IEC 61508 > High-Integrity Systems > Simulink > Check usage of Logic and Bit Operations blocks • By Task > Modeling Standards for IEC 62304 > High-Integrity Systems > Simulink > Check usage of Logic and Bit Operations blocks • By Task > Modeling Standards for ISO 26262 > High-Integrity Systems > Simulink > Check usage of Logic and Bit Operations blocks • By Task > Modeling Standards for EN 50128 > High-Integrity Systems > Simulink > Check usage of Logic and Bit Operations blocks <p>For DO-178C/DO-331 check details, see Check usage of Logic and Bit Operations blocks.</p> <p>For IEC 61508, IEC 62304, EN 50128, and ISO 26262 check details, see Check usage of Logic and Bit Operations blocks.</p>
<p>References</p>	<ul style="list-style-type: none"> • IEC 61508-3, Table A.3 (2) 'Strongly typed programming language' • IEC 61508-3, Table A.3 (3) 'Language subset' • IEC 61508-3, Table A.4 (3) 'Defensive programming' • IEC 62304, 5.5.3 - Software Unit acceptance criteria • ISO 26262-6, Table 1 (1b) 'Use of language subsets' • ISO 26262-6, Table 1 (1c) 'Enforcement of strong typing' • EN 50128, Table A.4 (11) 'Language Subset' • EN 50128, Table A.4 (8) 'Strongly Typed Programming Language' • EN 50128, Table A.3 (1) 'Defensive Programming' • DO-331, Section MB.6.3.1.g 'Algorithms are accurate' • DO-331, Section MB.6.3.2.g 'Algorithms are accurate' • MISRA C:2012, Dir 1.1
<p>See Also</p>	<p>"hisl_0017: Usage of blocks that compute relational operators (2)" on page 2-52</p>

ID: Title	hisl_0016: Usage of blocks that compute relational operators
Last Changed	R2018a
Examples	<p>Positive Pattern: To test whether two floating-point variables or expressions are equal, compare the difference of the two variables against a threshold that takes into account the floating-point relative accuracy (eps) and the magnitude of the numbers.</p> <p>The following pattern shows how to test two double-precision input signals, In1 and In2, for equality.</p>

hisl_0017: Usage of blocks that compute relational operators (2)

ID: Title	hisl_0017: Usage of blocks that compute relational operators (2)	
Description	To support unambiguous behavior in the generated code, when using blocks that compute relational operators, including Relational Operator, Compare To Constant, Compare to Zero, and Detect Change	
	A	Set the block Output data type parameter to Boolean.
	B	For Relational Operator blocks, ensure that all input signals are of the same data type.
Rationale	A, B	Support generation of code that produces unambiguous behavior.

ID: Title	hisl_0017: Usage of blocks that compute relational operators (2)
<p>Model Advisor Checks</p>	<ul style="list-style-type: none"> • By Task > Modeling Standards for DO-178C/DO-331 > High-Integrity Systems > Simulink > Check usage of Logic and Bit Operations blocks • By Task > Modeling Standards for IEC 61508 > High-Integrity Systems > Simulink > Check usage of Logic and Bit Operations blocks • By Task > Modeling Standards for IEC 62304 > High-Integrity Systems > Simulink > Check usage of Logic and Bit Operations blocks • By Task > Modeling Standards for ISO 26262 > High-Integrity Systems > Simulink > Check usage of Logic and Bit Operations blocks • By Task > Modeling Standards for EN 50128 > High-Integrity Systems > Simulink > Check usage of Logic and Bit Operations blocks <p>For DO-178C/DO-331 check details, see Check usage of Logic and Bit Operations blocks.</p> <p>For IEC 61508, IEC 62304, EN 50128, and ISO 26262 check details, see Check usage of Logic and Bit Operations blocks.</p>
<p>References</p>	<ul style="list-style-type: none"> • IEC 61508-3, Table A.3 (2) 'Strongly typed programming language' • IEC 61508-3, Table A.3 (3) 'Language subset' • IEC 61508-3, Table A.4 (3) 'Defensive programming' • IEC 62304, 5.5.3 - Software Unit acceptance criteria • ISO 26262-6, Table 1 (1b) 'Use of language subsets' • ISO 26262-6, Table 1 (1c) 'Enforcement of strong typing' • EN 50128, Table A.4 (11) 'Language Subset' • EN 50128, Table A.4 (8) 'Strongly Typed Programming Language' • EN 50128, Table A.3 (1) 'Defensive Programming' • DO-331, Section MB.6.3.1.g 'Algorithms are accurate' • DO-331, Section MB.6.3.2.g 'Algorithms are accurate' • MISRA C:2012, Rule 10.1
<p>See Also</p>	<p>"hisl_0016: Usage of blocks that compute relational operators" on page 2-50</p>

ID: Title	hisl_0017: Usage of blocks that compute relational operators (2)
Last Changed	R2018a

hisl_0018: Usage of Logical Operator block

ID: Title	hisl_0018: Usage of Logical Operator block	
Description	To support unambiguous behavior of generated code, when using the Logical Operator block,	
	A	Set the Output data type block parameter to Boolean.
	B	Ensure all input signals are of type Boolean.
Prerequisites	"hisl_0045: Configuration Parameters > Math and Data Types > Implement logic signals as Boolean data (vs. double)" on page 5-39	
Rationale	A, B	Avoid ambiguous behavior of generated code.
Model Advisor Checks	<ul style="list-style-type: none"> • By Task > Modeling Standards for DO-178C/DO-331 > High-Integrity Systems > Simulink > Check usage of Logic and Bit Operations blocks • By Task > Modeling Standards for IEC 61508 > High-Integrity Systems > Simulink > Check usage of Logic and Bit Operations blocks • By Task > Modeling Standards for IEC 62304 > High-Integrity Systems > Simulink > Check usage of Logic and Bit Operations blocks • By Task > Modeling Standards for ISO 26262 > High-Integrity Systems > Simulink > Check usage of Logic and Bit Operations blocks • By Task > Modeling Standards for EN 50128 > High-Integrity Systems > Simulink > Check usage of Logic and Bit Operations blocks <p>For DO-178C/DO-331 check details, see Check usage of Logic and Bit Operations blocks.</p> <p>For IEC 61508, IEC 62304, EN 50128, and ISO 26262 check details, see Check usage of Logic and Bit Operations blocks.</p>	

ID: Title	hisl_0018: Usage of Logical Operator block
References	<ul style="list-style-type: none"> • DO-331, Section MB.6.3.1.e—High-level requirements conform to standards DO-331, Section MB.6.3.2.e—Low-level requirements conform to standards DO-331, Section MB.6.3.1.g 'Algorithms are accurate' DO-331, Section MB.6.3.2.g 'Algorithms are accurate' DO-331, Section MB.6.3.4.e—Source code is traceable to low-level requirements. DO-331, Section MB.6.3.3.b—Software architecture is consistent. • IEC 61508-3, Table A.3 (2) 'Strongly typed programming language' IEC 61508-3, Table A.3 (3) 'Language subset' IEC 61508-3, Table A.4 (3) 'Defensive programming' • IEC 62304, 5.5.3 - Software Unit acceptance criteria • ISO 26262-6, Table 1 (1b) 'Use of language subsets' ISO 26262-6, Table 1 (1c) 'Enforcement of strong typing' • EN 50128, Table A.4 (11) 'Language Subset' EN 50128, Table A.4 (8) 'Strongly Typed Programming Language' EN 50128, Table A.3 (1) 'Defensive Programming' • MISRA C:2012, Directive 1.1
Last Changed	R2017b

hisl_0019: Usage of Bitwise Operator block

ID: Title	hisl_0019: Usage of Bitwise Operator block	
Description	To support unambiguous behavior, when using the Bitwise Operator block,	
	A	Avoid signed integer data types as input to the block.
Notes	Bitwise operations on signed integers are not meaningful. If a shift operation moves a signed bit into a numeric bit, or a numeric bit into a signed bit, unpredictable and unwanted behavior can result.	
Rationale	A	Support unambiguous behavior of generated code.

ID: Title	hisl_0019: Usage of Bitwise Operator block
References	<ul style="list-style-type: none">• DO-331, Section MB.6.3.1.g 'Algorithms are accurate'• DO-331, Section MB.6.3.2.g 'Algorithms are accurate'• IEC 61508-3, Table A.3 (3) 'Language subset'• IEC 61508-3, Table A.3 (2) 'Strongly typed programming language'• IEC 62304, 5.5.3 - Software Unit acceptance criteria• ISO 26262-6, Table 1 (1b) 'Use of language subsets'• ISO 26262-6, Table 1 (1c) 'Enforcement of strong typing'• ISO 26262-6, Table 1 (1d) 'Use of defensive implementation techniques'• EN 50128, Table A.4 (11) 'Language Subset'• EN 50128, Table A.3 (1) 'Defensive Programming'• EN 50128, Table A.4 (8) 'Strongly Typed Programming Language'• MISRA C:2012, Rule 10.1
See Also	"hisf_0003: Usage of bitwise operations" on page 3-12 in the Simulink documentation
Last Changed	R2018a

Lookup Table Blocks

hisl_0033: Usage of Lookup Table blocks

ID: Title	hisl_0033: Usage of Lookup Table blocks	
Description	To support robustness of generated code, when using the 1-D Lookup Table, 2-D Lookup Table, n-D Lookup Table, Prelookup, and Interpolation Using Prelookup blocks:	
	A	In each 1-D Lookup Table, 2-D Lookup Table, n-D Lookup Table, or Prelookup block, verify that Remove protection against out-of-range input in generated code is cleared.
	B	In each Interpolation Using Prelookup block, verify that Remove protection against out-of-range index in generated code is cleared.
Note	If the lookup table inputs are not guaranteed to fall within the range of valid breakpoint values, exclusion of range-checking code may produce unexpected results.	
Rationale	A,B	Protect against out-of-range inputs or indices.
Model Advisor Checks	<ul style="list-style-type: none"> • By Task > Modeling Standards for DO-178C/DO-331 > High-Integrity Systems > Simulink > Check usage of lookup table blocks • By Task > Modeling Standards for IEC 61508 > High-Integrity Systems > Simulink > Check usage of lookup table blocks • By Task > Modeling Standards for IEC 62304 > High-Integrity Systems > Simulink > Check usage of lookup table blocks • By Task > Modeling Standards for EN 50128 > High-Integrity Systems > Simulink > Check usage of lookup table blocks • By Task > Modeling Standards for ISO 26262 > High-Integrity Systems > Simulink > Check usage of lookup table blocks <p>For DO-178C/DO-331 check details, see Check usage of lookup table blocks.</p> <p>For IEC 61508, IEC 62304, EN 50128, and ISO 26262 check details, see Check usage of lookup table blocks.</p>	

ID: Title	hisl_0033: Usage of Lookup Table blocks
References	<ul style="list-style-type: none">• DO-331, Sections MB.6.3.1.g and MB.6.3.2.g 'Algorithms are accurate'• IEC 61508-3, Table A.3 (3) 'Language subset' IEC 61508-3, Table A.4 (3) 'Defensive programming'• IEC 62304, 5.5.3 - Software Unit acceptance criteria• ISO 26262-6, Table 1 (1b) 'Use of language subsets' ISO 26262-6, Table 1 (1d) 'Use of defensive implementation techniques'• EN 50128, Table A.4 (11) 'Language Subset' EN 50128, Table A.3 (1) 'Defensive Programming'
Last Changed	R2017b

Stateflow Chart Considerations

- “Chart Properties” on page 3-2
- “Chart Architecture” on page 3-12

Chart Properties

In this section...
“hisf_0001: Mealy and Moore semantics” on page 3-2
“hisf_0002: User-specified state/transition execution order” on page 3-4
“hisf_0009: Strong data typing (Simulink and Stateflow boundary)” on page 3-6
“hisf_0011: Stateflow debugging settings” on page 3-8

hisf_0001: Mealy and Moore semantics

ID: Title	hisf_0001: Mealy and Moore semantics	
Description	To create Stateflow charts that implement a subset of Stateflow semantics,	
	A	In the Chart properties dialog box, set State Machine Type to Mealy or Moore.
	B	Apply consistent settings to the Stateflow charts in a model.
Note	<p>Setting State Machine Type restricts the Stateflow semantics to pure Mealy or Moore semantics. Mealy and Moore charts might be easier to understand and use in high-integrity applications.</p> <p>In Mealy charts, actions are associated with transitions. In the Moore charts, actions are associated with states.</p> <p>At compile time, the Stateflow software verifies that the chart semantics comply with the formal definitions and rules of the selected type of state machine. If the chart semantics are not in compliance, the software provides a diagnostic message.</p>	
Rationale	A, B	Promote a clear modeling style.

ID: Title	hisf_0001: Mealy and Moore semantics
Model Advisor Checks	<ul style="list-style-type: none"> • By Task > Modeling Standards for DO-178C/DO-331 > High-Integrity Systems > Stateflow > Check state machine type of Stateflow charts • By Task > Modeling Standards for IEC 61508 > High-Integrity Systems > Stateflow > Check state machine type of Stateflow charts • By Task > Modeling Standards for IEC 62304 > High-Integrity Systems > Stateflow > Check state machine type of Stateflow charts • By Task > Modeling Standards for ISO 26262 > High-Integrity Systems > Stateflow > Check state machine type of Stateflow charts • By Task > Modeling Standards for EN 50128 > High-Integrity Systems > Stateflow > Check state machine type of Stateflow charts <p>For DO-178C/DO-331 check details, see Check state machine type of Stateflow charts.</p> <p>For IEC 61508, IEC 62304, EN 50128, and ISO 26262 check details, see Check state machine type of Stateflow charts.</p>
References	<ul style="list-style-type: none"> • IEC 61508-3, Table A.3 (3) - Language subset • IEC 62304, 5.5.3 - Software Unit acceptance criteria • ISO 26262-6, Table 1 (1b) 'Use of language subsets' • EN 50128, Table A.4 (11) 'Language Subset' • DO-331, Section MB.6.3.1.b 'High-level requirements are accurate and consistent' • DO-331, Section MB.6.3.1.e 'High-level requirements conform to standards' • DO-331, Section MB.6.3.2.b 'Low-level requirements are accurate and consistent' • DO-331, Section MB.6.3.2.e 'Low-level requirements conform to standards' • DO-331, Section MB.6.3.3.b 'Software architecture is consistent' • DO-331, Section MB.6.3.3.e 'Software architecture conform to standards'
See Also	"Create Mealy and Moore Charts" (Stateflow)
Last Changed	R2016a

hisf_0002: User-specified state/transition execution order

ID: Title	hisf_0002: User-specified state/transition execution order	
Description	Do the following to explicitly set the execution order for active states and valid transitions in Stateflow charts:	
	A	In the Chart Properties dialog box, select User specified state/transition execution order .
	B	In the Stateflow Editor, select Display > Chart > Transition Execution Order .
	C	Set default transition to evaluate last.
Note	<p>Selecting User specified state/transition execution order in the Chart properties dialog box restricts the dependency of a Stateflow chart semantics on the geometric position of parallel states and transitions.</p> <p>Specifying the execution order of states and transitions allows you to enforce determinism in the search order for active states and valid transitions. You have control of the order in which parallel states are executed and transitions originating from a source are tested for execution. If you do not explicitly set the execution order, the Stateflow software determines the execution order following a deterministic algorithm.</p> <p>Selecting Display > Chart > Transition Execution Order displays the transition testing order.</p>	
Rationale	A, B, C	Promote an unambiguous modeling style.

ID: Title	hisf_0002: User-specified state/transition execution order
Model Advisor Checks	<ul style="list-style-type: none"> • By Task > Modeling Standards for DO-178C/DO-331 > High-Integrity Systems > Stateflow > Check Stateflow charts for ordering of states and transitions • By Task > Modeling Standards for IEC 61508 > High-Integrity Systems > Stateflow > Check Stateflow charts for ordering of states and transitions • By Task > Modeling Standards for IEC 62304 > High-Integrity Systems > Stateflow > Check Stateflow charts for ordering of states and transitions • By Task > Modeling Standards for ISO 26262 > High-Integrity Systems > Stateflow > Check Stateflow charts for ordering of states and transitions • By Task > Modeling Standards for EN 50128 > High-Integrity Systems > Stateflow > Check Stateflow charts for ordering of states and transitions <p>For DO-178C/DO-331 check details, see Check Stateflow charts for ordering of states and transitions.</p> <p>For IEC 61508, IEC 62304, EN 50128, and ISO 26262 check details, see Check Stateflow charts for ordering of states and transitions.</p>
	<ul style="list-style-type: none"> • By Task > Modeling Standards for DO-178C/DO-331 > High-Integrity Systems > Stateflow > Check usage of Stateflow constructs • By Task > Modeling Standards for IEC 61508 > High-Integrity Systems > Stateflow > Check usage of Stateflow constructs • By Task > Modeling Standards for IEC 62304 > High-Integrity Systems > Stateflow > Check usage of Stateflow constructs • By Task > Modeling Standards for ISO 26262 > High-Integrity Systems > Stateflow > Check usage of Stateflow constructs • By Task > Modeling Standards for EN 50128 > High-Integrity Systems > Stateflow > Check usage of Stateflow constructs <p>For DO-178C/DO-331 check details, see Check usage of Stateflow constructs.</p> <p>For IEC 61508, IEC 62304, EN 50128, and ISO 26262 check details, see Check usage of Stateflow constructs.</p>

ID: Title	hisf_0002: User-specified state/transition execution order
References	<p>This guideline supports adhering to:</p> <ul style="list-style-type: none"> • DO-331, Section MB.6.3.2.b 'Low-level requirements are accurate and consistent' • DO-331, Section MB.6.3.3.b 'Software architecture is consistent' • DO-331, Section MB.6.3.3.e 'Software architecture conform to standards ' • IEC 61508-3, Table A.3 (3) 'Language subset' • IEC 61508-3, Table A.4 (5) 'Design and coding standards' • IEC 62304, 5.5.3 - Software Unit acceptance criteria • ISO 26262-6, Table 1 (1b) 'Use of language subsets' • ISO 26262-6, Table 1 (1e) 'Use of established design principles' • ISO 26262-6, Table 1 (1f) 'Use of unambiguous graphical representation' • ISO 26262-6, Table 1 (1g) 'Use of style guides' • ISO 26262-6, Table 1 (1h) 'Use of naming conventions' • EN 50128, Table A.4 (11) 'Language Subset' • EN 50128, Table A.12 (1) 'Coding Standard' • EN 50128, Table A.12 (2) 'Coding Style Guide'
See Also	<p>The following topics in the Stateflow documentation</p> <ul style="list-style-type: none"> • “Evaluate Transitions” (Stateflow) • “Execution Order for Parallel States” (Stateflow)
Last Changed	R2018a

hisf_0009: Strong data typing (Simulink and Stateflow boundary)

ID: Title	hisf_0009: Strong data typing (Simulink and Stateflow boundary)	
Description	To support strong data typing between Simulink and Stateflow ,	
	A	Select Use Strong Data Typing with Simulink I/O .

ID: Title	hisf_0009: Strong data typing (Simulink and Stateflow boundary)	
Notes	By default, input to and output from Stateflow charts are of type <code>double</code> . To interface directly with Simulink signals of data types other than <code>double</code> , select Use Strong Data Typing with Simulink I/O . In this mode, data types between the Simulink and Stateflow boundary are strongly typed, and the Simulink software does not treat the data types as <code>double</code> . The Stateflow chart accepts input signals of any data type supported by the Simulink software, provided that the type of the input signal matches the type of the corresponding Stateflow input data object. Otherwise, the software reports a type mismatch error.	
Rationale	A	Support strongly typed code.
Model Advisor Checks	<ul style="list-style-type: none"> • By Task > Modeling Standards for DO-178C/DO-331 > High-Integrity Systems > Stateflow > Check usage of Stateflow constructs • By Task > Modeling Standards for IEC 61508 > High-Integrity Systems > Stateflow > Check usage of Stateflow constructs • By Task > Modeling Standards for IEC 62304 > High-Integrity Systems > Stateflow > Check usage of Stateflow constructs • By Task > Modeling Standards for ISO 26262 > High-Integrity Systems > Stateflow > Check usage of Stateflow constructs • By Task > Modeling Standards for EN 50128 > High-Integrity Systems > Stateflow > Check usage of Stateflow constructs <p>For DO-178C/DO-331 check details, see Check usage of Stateflow constructs.</p> <p>For IEC 61508, IEC 62304, EN 50128, and ISO 26262 check details, see Check usage of Stateflow constructs.</p>	

ID: Title	hisf_0009: Strong data typing (Simulink and Stateflow boundary)
References	<ul style="list-style-type: none"> • DO-331, Section MB.6.3.1.b 'High-level requirements are accurate and consistent' DO-331, Section MB.6.3.1.e 'High-level requirements conform to standards' DO-331, Section MB.6.3.1.g 'Algorithms are accurate' DO-331, Section MB.6.3.2.b 'Low-level requirements are accurate and consistent' DO-331, Section MB.6.3.2.e 'Low-level requirements conform to standards' DO-331, Section MB.6.3.2.g 'Algorithms are accurate' • IEC 61508-3, Table A.3 (2) 'Strongly typed programming language' IEC 61508-3, Table A.3 (3) - Language subset IEC 61508-3, Table A.4 (5) - Design and coding standards • IEC 62304, 5.5.3 - Software Unit acceptance criteria • ISO 26262-6, Table 1 (1b) - Use of language subsets ISO 26262-6, Table 1 (1c) 'Enforcement of strong typing' ISO 26262-6, Table 1 (1d) - Use of defensive implementation techniques ISO 26262-6, Table 1 (1e) - Use of established design principles ISO 26262-6, Table 1 (1f) - Use of unambiguous graphical representation ISO 26262-6, Table 1 (1g) - Use of style guides ISO 26262-6, Table 1 (1h) - Use of naming conventions • EN 50128, Table A.3 (1) - Defensive Programming EN 50128, Table A.4 (8) 'Strongly Typed Programming Language' EN 50128, Table A.4 (11) - Language Subset
Last Changed	R2017b

hisf_0011: Stateflow debugging settings

ID: Title	hisf_0011: Stateflow debugging settings
Description	<p>To protect against unreachable code and indeterminate execution time,</p> <p>A In the Configuration Parameters dialog box, set:</p> <ul style="list-style-type: none"> • Diagnostics > Data Validity > Wrap on overflow to error. • Diagnostics > Data Validity > Simulation range checking to error. • In the model window, select: <ul style="list-style-type: none"> • Simulation > Debug > MATLAB & Stateflow Error Checking Options > Detect Cycles.

ID: Title	hisf_0011: Stateflow debugging settings
	<p>For each truth table in the model, in the Settings menu of the Truth Table Editor, set the following parameters to Error:</p> <p>Underspecified</p> <p>Overspecified</p>
Notes	<p>Run-time diagnostics are only triggered during simulation. If the error condition is not reached during simulation, the error message is not triggered for code generation.</p>
Rationale	<p>Protect against unreachable code and unpredictable execution time.</p>
Model Advisor Checks	<ul style="list-style-type: none"> • By Task > Modeling Standards for DO-178C/DO-331 > High-Integrity Systems > Stateflow > Check Stateflow debugging options • By Task > Modeling Standards for IEC 61508 > High-Integrity Systems > Stateflow > Check Stateflow debugging options • By Task > Modeling Standards for IEC 62304 > High-Integrity Systems > Stateflow > Check Stateflow debugging options • By Task > Modeling Standards for ISO 26262 > High-Integrity Systems > Stateflow > Check Stateflow debugging options • By Task > Modeling Standards for EN 50128 > High-Integrity Systems > Stateflow > Check Stateflow debugging options <p>For DO-178C/DO-331 check details, see Check Stateflow debugging options.</p> <p>For IEC 61508, IEC 62304, EN 50128, and ISO 26262 check details, see Check Stateflow debugging options.</p>

ID: Title	hisf_0011: Stateflow debugging settings
	<ul style="list-style-type: none"> • By Task > Modeling Standards for DO-178C/DO-331 > High-Integrity Systems > Stateflow > Check usage of Stateflow constructs • By Task > Modeling Standards for IEC 61508 > High-Integrity Systems > Stateflow > Check usage of Stateflow constructs • By Task > Modeling Standards for IEC 62304 > High-Integrity Systems > Stateflow > Check usage of Stateflow constructs • By Task > Modeling Standards for ISO 26262 > High-Integrity Systems > Stateflow > Check usage of Stateflow constructs • By Task > Modeling Standards for EN 50128 > High-Integrity Systems > Stateflow > Check usage of Stateflow constructs <p>For DO-178C/DO-331 check details, see Check usage of Stateflow constructs.</p> <p>For IEC 61508, IEC 62304, EN 50128, and ISO 26262 check details, see Check usage of Stateflow constructs.</p>
References	<ul style="list-style-type: none"> • DO-331, Section MB.6.3.1.b 'High-level requirements are accurate and consistent' • DO-331, Section MB.6.3.1.e 'High-level requirements conform to standards' • DO-331, Section MB.6.3.2.b 'Low-level requirements are accurate and consistent' • DO-331, Section MB.6.3.2.e 'Low-level requirements conform to standards' • IEC 61508-3, Table A.3 (2) 'Strongly typed programming language' • IEC 61508-3, Table A.3 (3) - Language subset • IEC 61508-3, Table A.4 (5) - Design and coding standards • IEC 62304, 5.5.3 - Software Unit acceptance criteria • ISO 26262-6, Table 1 (1b) - Use of language subsets • ISO 26262-6, Table 1 (1c) 'Enforcement of strong typing' • ISO 26262-6, Table 1 (1d) - Use of defensive implementation techniques • ISO 26262-6, Table 1 (1e) - Use of established design principles • ISO 26262-6, Table 1 (1f) - Use of unambiguous graphical representation • ISO 26262-6, Table 1 (1g) - Use of style guides • ISO 26262-6, Table 1 (1h) - Use of naming conventions • EN 50128, Table A.3 (1) - Defensive Programming • EN 50128, Table A.4 (8) 'Strongly Typed Programming Language' • EN 50128, Table A.4 (11) - Language Subset

ID: Title	hisf_0011: Stateflow debugging settings
Last Changed	R2017b

Chart Architecture

In this section...
“hisf_0003: Usage of bitwise operations” on page 3-12
“hisf_0004: Usage of recursive behavior” on page 3-13
“hisf_0007: Usage of junction conditions (maintaining mutual exclusion)” on page 3-15
“hisf_0013: Usage of transition paths (crossing parallel state boundaries)” on page 3-16
“hisf_0014: Usage of transition paths (passing through states)” on page 3-19
“hisf_0015: Strong data typing (casting variables and parameters in expressions)” on page 3-20
“hisf_0016: Stateflow port names” on page 3-22
“hisf_0017: Stateflow data object scoping” on page 3-23

hisf_0003: Usage of bitwise operations

ID: Title	hisf_0003: Usage of bitwise operations	
Description	When using bitwise operations in Stateflow blocks,	
	A	Avoid signed integer data types as operands to the bitwise operations.
Notes	Normally, bitwise operations are not meaningful on signed integers. Undesired behavior can occur. For example, a shift operation might move the sign bit into the number, or a numeric bit into the sign bit.	
Rationale	A	Promote unambiguous modeling style.
Model Advisor Checks	<ul style="list-style-type: none"> • By Task > Modeling Standards for MAAB > Stateflow > Check for bitwise operations in Stateflow charts • By Task > Modeling Standards for JMAAB > Stateflow > Check for bitwise operations in Stateflow charts <p>For MAAB, see Check for bitwise operations in Stateflow charts.</p> <p>JMAAB, see Check for bitwise operations in Stateflow charts .</p>	

ID: Title	hisf_0003: Usage of bitwise operations
References	<ul style="list-style-type: none"> IEC 61508-3, Table A.3 (3) 'Language subset' IEC 61508-3, Table A.3 (2) 'Strongly typed programming language' IEC 62304, 5.5.3 - Software Unit acceptance criteria ISO 26262-6, Table 1 (1b) 'Use of language subsets' ISO 26262-6, Table 1 (1c) 'Enforcement of strong typing' EN 50128, Table A.4 (11) 'Language Subset' EN 50128, Table A.3 (1) 'Defensive Programming' DO-331, Section MB.6.3.1.b 'High-level requirements are accurate and consistent' DO-331, Section MB.6.3.1.e 'High-level requirements conform to standards' DO-331, Section 6.3.1.g 'Algorithms are accurate' DO-331, Section MB.6.3.2.b 'Low-level requirements are accurate and consistent' DO-331, Section MB.6.3.2.e 'Low-level requirements conform to standards' DO-331, Section MB.6.3.2.g 'Algorithms are accurate' MISRA C:2012, Rule 10.1
See Also	"hisf_0019: Usage of Bitwise Operator block" on page 2-55
Last Changed	R2016a

hisf_0004: Usage of recursive behavior

ID: Title	hisf_0004: Usage of recursive behavior	
Description	To support bounded function call behavior, avoid using design patterns that include unbounded recursive behavior. Recursive behavior is bound if you do the following:	
	A	Use an explicit termination condition that is local to the recursive call.
	B	Make sure the termination condition is reached.
Notes	This rule only applies if a chart is a classic Stateflow chart. If "hisf_0001: Mealy and Moore semantics" on page 3-2 is followed, recursive behavior is prevented due to restrictions in the chart semantics. Additionally, you can detect the error during simulation by enabling the Stateflow diagnostic Detect Cycles .	
Rationale	A, B	Promote bounded function call behavior.

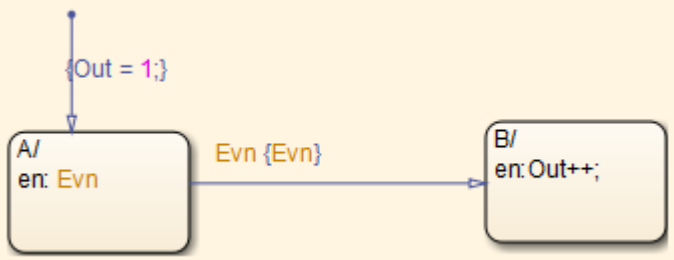
ID: Title	hisf_0004: Usage of recursive behavior
References	<ul style="list-style-type: none"> • IEC 61508-3, Table B.1 (6) 'Limited use of recursion' • IEC 62304, 5.5.3 - Software Unit acceptance criteria • ISO 26262-6, Table 8 (1j) 'No recursions' • EN 50128, Table A.12 (6) 'Limited Use of Recursion' • DO-331, Section MB.6.3.1.b 'High-level requirements are accurate and consistent' • DO-331, Section MB.6.3.1.e 'High-level requirements conform to standards' • DO-331, Section MB.6.3.1.g 'Algorithms are accurate' • DO-331, Section MB.6.3.2.b 'Low-level requirements are accurate and consistent' • DO-331, Section MB.6.3.2.e 'Low-level requirements conform to standards' • DO-331, Section MB.6.3.2.g 'Algorithms are accurate' • MISRA C:2012, Rule 17.2
Last Changed	R2016a
Examples	<p>There are multiple patterns in Stateflow that can result in unbounded recursion.</p>  <p>Recursive Function Calls</p>

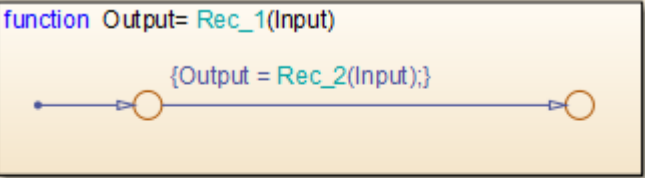
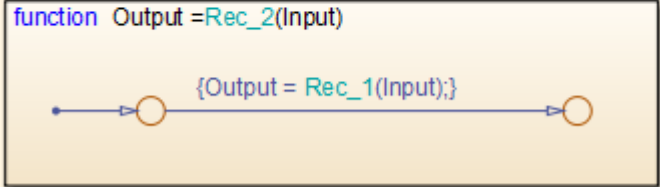
ID: Title	hisf_0004: Usage of recursive behavior
	<p>When the default state A is entered, event Evn is broadcast in the entry action of A. Evn results in a recursive call of the interpretation algorithm. Since A is active, the outgoing transition of A is tested. Since the current event Evn matches the transition event (and because of the absence of condition) the condition action is executed, broadcasting Evn again. This results in a new call of the interpretation algorithm which repeats the same sequence of steps until stack overflow.</p> <div style="border: 1px solid black; padding: 5px; margin: 10px 0;"> <pre>function Output= Rec_1(Input) {Output = Rec_2(Input);} </pre>  </div> <div style="border: 1px solid black; padding: 5px; margin: 10px 0;"> <pre>function Output =Rec_2(Input) {Output = Rec_1(Input);} </pre>  </div> <p>Recursive Function Calls</p>

hisf_0007: Usage of junction conditions (maintaining mutual exclusion)

ID: Title	hisf_0007: Usage of junction conditions (maintaining mutual exclusion)	
Description	To enhance clarity and prevent the generation of unreachable code,	
	A	Make junction conditions mutually exclusive.
Notes	You can use this guideline to maintain a modeling language subset in high-integrity projects.	
Rationale	A	Enhance clarity and prevent generation of unreachable code.

ID: Title	hisf_0007: Usage of junction conditions (maintaining mutual exclusion)
References	<ul style="list-style-type: none"> • DO-331, Section MB.6.3.1.b 'High-level requirements are accurate and consistent' DO-331, Section MB.6.3.1.d 'High-level requirements are verifiable' DO-331, Section MB.6.3.1.e 'High-level requirements conform to standards' DO-331, Section MB.6.3.2.b 'Low-level requirements are accurate and consistent' DO-331, Section MB.6.3.2.d 'Low-level requirements are verifiable' DO-331, Section MB.6.3.2.e 'Low-level requirements conform to standards'
Last Changed	R2012b

hisf_0013: Usage of transition paths (crossing parallel state boundaries)

ID: Title	hisf_0013: Usage of transition paths (crossing parallel state boundaries)	
Description	To avoid creating diagrams that are hard to understand,	
Notes	A	Avoid creating transitions that cross from one parallel state to another.
Rationale	A	Enhance model readability.

ID: Title	hisf_0013: Usage of transition paths (crossing parallel state boundaries)
Model Advisor Checks	<ul style="list-style-type: none"> • By Task > Modeling Standards for DO-178C/DO-331 > High-Integrity Systems > Stateflow > Check Stateflow charts for transition paths that cross parallel state boundaries • By Task > Modeling Standards for IEC 61508 > High-Integrity Systems > Stateflow > Check Stateflow charts for transition paths that cross parallel state boundaries • By Task > Modeling Standards for IEC 62304 > High-Integrity Systems > Stateflow > Check Stateflow charts for transition paths that cross parallel state boundaries • By Task > Modeling Standards for ISO 26262 > High-Integrity Systems > Stateflow > Check Stateflow charts for transition paths that cross parallel state boundaries • By Task > Modeling Standards for EN 50128 > High-Integrity Systems > Stateflow > Check Stateflow charts for transition paths that cross parallel state boundaries <p>For DO-178C/DO-331 check details, see Check Stateflow charts for transition paths that cross parallel state boundaries .</p> <p>For IEC 61508, IEC 62304, EN 50128, and ISO 26262 check details, see Check Stateflow charts for transition paths that cross parallel state boundaries.</p>
References	<ul style="list-style-type: none"> • IEC 61508-3, Table A.3 (3) 'Language subset' • IEC 62304, 5.5.3 - Software Unit acceptance criteria • ISO 26262-6, Table 1 (1b) 'Use of language subsets' • EN 50128, Table A.4 (11) 'Language Subset' • DO-331, Section MB.6.3.1.b 'High-level requirements are accurate and consistent' • DO-331, Section MB.6.3.1.e 'High-level requirements conform to standards' • DO-331, Section MB.6.3.2.b 'Low-level requirements are accurate and consistent' • DO-331, Section MB.6.3.2.e 'Low-level requirements conform to standards'
Last Changed	R2017b

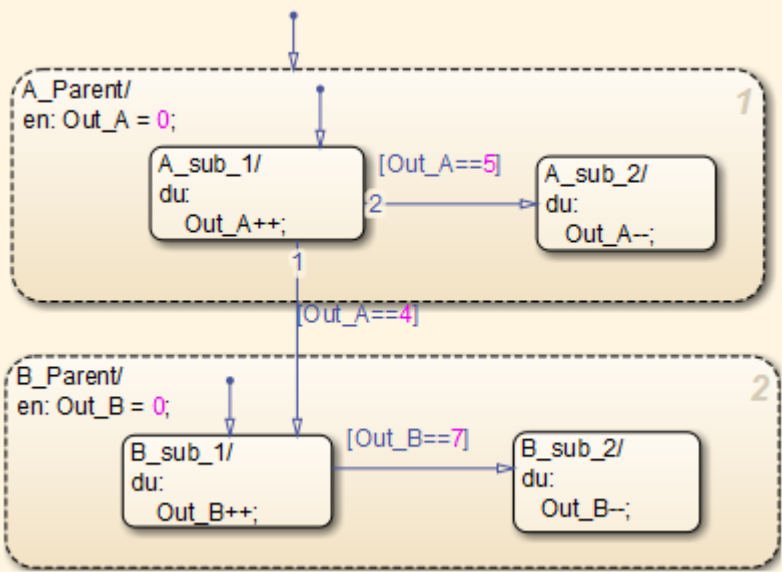
ID: Title	hisf_0013: Usage of transition paths (crossing parallel state boundaries)
Example	<p>In the following example, when Out_A is 4, both parent states (A_Parent and B_Parent) are reentered. Reentering the parent states resets the values of Out_A and Out_B to zero.</p>  <pre> stateDiagram-v2 state A_Parent { [*] --> A_sub_1 A_sub_1 --> A_sub_2 : [Out_A==5] A_sub_2 --> A_Parent } state B_Parent { [*] --> B_sub_1 B_sub_1 --> B_sub_2 : [Out_B==7] B_sub_2 --> B_Parent } A_Parent --> B_Parent : [Out_A==4] </pre> <p>The diagram illustrates a stateflow chart with two parallel parent states, A_Parent and B_Parent, each containing two sub-states. A transition from A_sub_1 to B_sub_1 is labeled [Out_A==4], indicating a cross-boundary transition.</p> <p>A_Parent (1): en: Out_A = 0; A_sub_1/ du: Out_A++; A_sub_2/ du: Out_A--;</p> <p>B_Parent (2): en: Out_B = 0; B_sub_1/ du: Out_B++; B_sub_2/ du: Out_B--;</p>

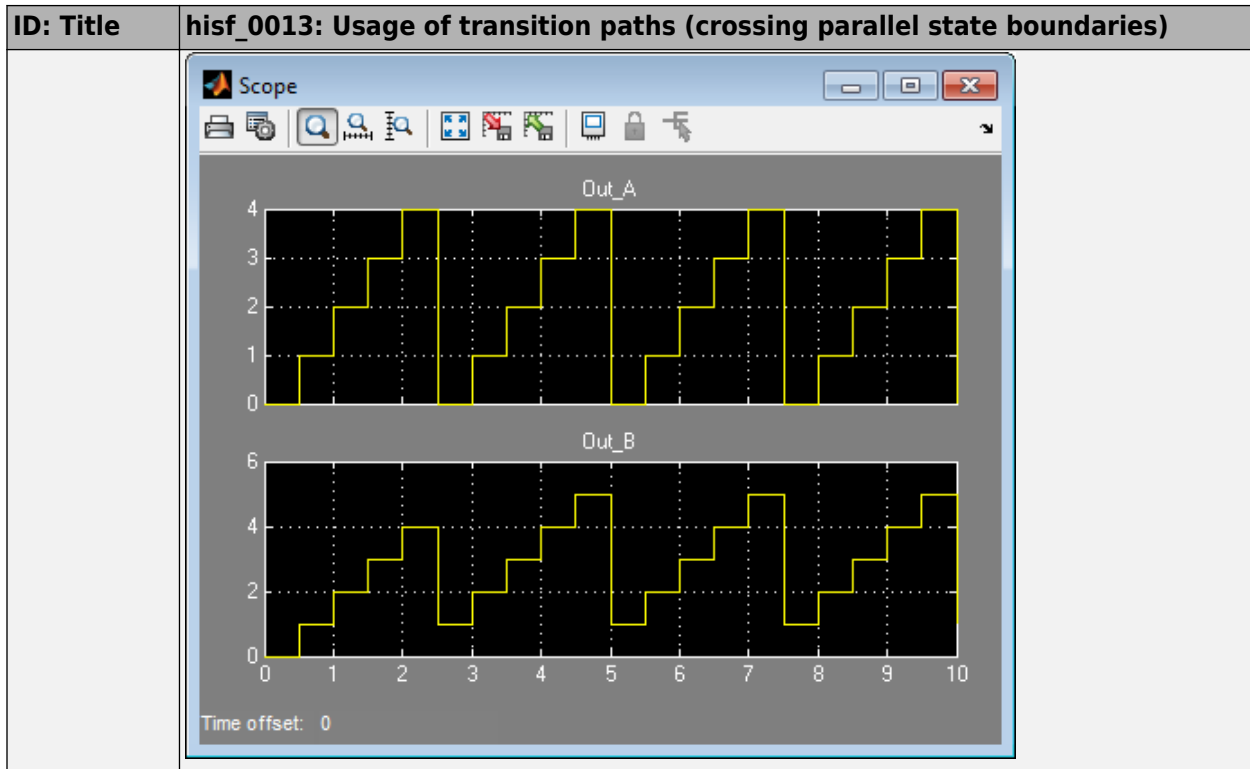

hisf_0014: Usage of transition paths (passing through states)

ID: Title	hisf_0014: Usage of transition paths (passing through states)	
Description	To avoid creating diagrams that are confusing and include transition paths without benefit,	
	A	Avoid transition paths that go into and out of a state without ending on a substate.
Notes	You can use this guideline to maintain a modeling language subset in high-integrity projects.	
Rationale	A	Enhance model readability.

ID: Title	hisf_0014: Usage of transition paths (passing through states)
References	<ul style="list-style-type: none"> • IEC 61508-3, Table A.3 (3) 'Language subset' • IEC 62304, 5.5.3 - Software Unit acceptance criteria • ISO 26262-6, Table 1 (1b) 'Use of language subsets' • EN 50128, Table A.4 (11) 'Language Subset' • DO-331, Section MB.6.3.1.b 'High-level requirements are accurate and consistent' • DO-331, Section MB.6.3.1.e 'High-level requirements conform to standards' • DO-331, Section MB.6.3.2.b 'Low-level requirements are accurate and consistent' • DO-331, Section MB.6.3.2.e 'Low-level requirements conform to standards'
Last Changed	R2016a
Examples	

hisf_0015: Strong data typing (casting variables and parameters in expressions)

ID: Title	hisf_0015: Strong data typing (casting variables and parameters in expressions)			
Description	To facilitate strong data typing, <table border="1" data-bbox="284 1211 1345 1397"> <tr> <td data-bbox="284 1211 417 1397">A</td> <td data-bbox="422 1211 1345 1397"> Explicitly type cast variables and parameters of different data types in: <ul style="list-style-type: none"> • Transition evaluations • Transition assignments • Assignments in states </td> </tr> </table>		A	Explicitly type cast variables and parameters of different data types in: <ul style="list-style-type: none"> • Transition evaluations • Transition assignments • Assignments in states
A	Explicitly type cast variables and parameters of different data types in: <ul style="list-style-type: none"> • Transition evaluations • Transition assignments • Assignments in states 			
Notes	The Stateflow software automatically casts variables of different type into the same data type. This guideline helps clarify data types of the intermediate variables.			
Rationale	A	Apply strong data typing.		

ID: Title	hisf_0015: Strong data typing (casting variables and parameters in expressions)
Model Advisor Checks	<ul style="list-style-type: none"> • By Task > Modeling Standards for DO-178C/DO-331 > High-Integrity Systems > Stateflow > Check Stateflow charts for strong data typing • By Task > Modeling Standards for IEC 61508 > High-Integrity Systems > Stateflow > Check Stateflow charts for strong data typing • By Task > Modeling Standards for IEC 62304 > High-Integrity Systems > Stateflow > Check Stateflow charts for strong data typing • By Task > Modeling Standards for ISO 26262 > High-Integrity Systems > Stateflow > Check Stateflow charts for strong data typing • By Task > Modeling Standards for EN 50128 > High-Integrity Systems > Stateflow > Check Stateflow charts for strong data typing <p>For DO-178C/DO-331 check details, see Check Stateflow charts for strong data typing.</p> <p>For IEC 61508, IEC 62304, EN 50128, and ISO 26262 check details, see Check Stateflow charts for strong data typing.</p>
References	<ul style="list-style-type: none"> • IEC 61508-3, Table A.3 (2) 'Strongly typed programming language' • IEC 62304, 5.5.3 - Software Unit acceptance criteria • ISO 26262-6, Table 1 (1c) 'Enforcement of strong typing' • EN 50128, Table A.4 (8) 'Strongly Typed Programming Language' • DO-331, Section MB.6.3.1.b 'High-level requirements are accurate and consistent' • DO-331, Section MB.6.3.1.e 'High-level requirements conform to standards' • DO-331, Section MB.6.3.1.g 'Algorithms are accurate' • DO-331, Section MB.6.3.2.b 'Low-level requirements are accurate and consistent' • DO-331, Section MB.6.3.2.e 'Low-level requirements conform to standards' • DO-331, Section MB.6.3.2.g 'Algorithms are accurate'
Last Changed	R2017b

ID: Title	hisf_0015: Strong data typing (casting variables and parameters in expressions)
Examples	<div style="background-color: #ffffcc; padding: 10px; margin-bottom: 10px;"> <pre> graph TD Start(()) --> State_A[State_A/] State_A -- "[uint16(uint_8_Var) < uint_16_Var]" --> State_B[State_B/] </pre> </div> <p>Recommended</p> <div style="background-color: #ffffcc; padding: 10px; margin-bottom: 10px;"> <pre> graph TD Start(()) --> State_A1[State_A1/] State_A1 -- "[int_8_Var < int_16_Var]" --> State_B1[State_B1/] </pre> </div> <p>Not Recommended</p>

hisf_0016: Stateflow port names

ID: Title	hisf_0016: Stateflow port names
Description	<p>The name of a Stateflow input or output must be the same as the corresponding signal.</p> <p>Exception: Reusable Stateflow blocks can have different port names.</p>
Rationale	Support generation of traceable code.

ID: Title	hisf_0016: Stateflow port names
Model Advisor Checks	<ul style="list-style-type: none"> • By Task > Modeling Standards for DO-178C/DO-331 > High-Integrity Systems > Stateflow > Check usage of Stateflow constructs • By Task > Modeling Standards for IEC 61508 > High-Integrity Systems > Stateflow > Check usage of Stateflow constructs • By Task > Modeling Standards for IEC 62304 > High-Integrity Systems > Stateflow > Check usage of Stateflow constructs • By Task > Modeling Standards for ISO 26262 > High-Integrity Systems > Stateflow > Check usage of Stateflow constructs • By Task > Modeling Standards for EN 50128 > High-Integrity Systems > Stateflow > Check usage of Stateflow constructs <p>For DO-178C/DO-331 check details, see Check usage of Stateflow constructs.</p> <p>For IEC 61508, IEC 62304, EN 50128, and ISO 26262 check details, see Check usage of Stateflow constructs.</p>
References	<ul style="list-style-type: none"> • DO-331, Section MB.6.3.2.b 'Low-level requirements are accurate and consistent' • IEC 61508-3, Table A.3 (3) 'Language subset' • IEC 62304, 5.5.3 - Software Unit acceptance criteria • ISO 26262-6, Table 1 (1b) 'Use of language subsets' • EN 50128, Table A.4 (11) 'Language Subset'
Last Changed	2018a

hisf_0017: Stateflow data object scoping

ID: Title	hisf_0017: Stateflow data object scoping
Description	Stateflow data objects with local scope must be defined at the chart level or below.
Rationale	Support generation of traceable code.

ID: Title	hisf_0017: Stateflow data object scoping
Model Advisor Checks	<ul style="list-style-type: none"> • By Task > Modeling Standards for DO-178C/DO-331 > High-Integrity Systems > Stateflow > Check usage of Stateflow constructs • By Task > Modeling Standards for IEC 61508 > High-Integrity Systems > Stateflow > Check usage of Stateflow constructs • By Task > Modeling Standards for IEC 62304 > High-Integrity Systems > Stateflow > Check usage of Stateflow constructs • By Task > Modeling Standards for ISO 26262 > High-Integrity Systems > Stateflow > Check usage of Stateflow constructs • By Task > Modeling Standards for EN 50128 > High-Integrity Systems > Stateflow > Check usage of Stateflow constructs <p>For DO-178C/DO-331 check details, see Check usage of Stateflow constructs.</p> <p>For IEC 61508, IEC 62304, EN 50128, and ISO 26262 check details, see Check usage of Stateflow constructs.</p>
References	<ul style="list-style-type: none"> • DO-331, Section MB.6.3.2.b 'Low-level requirements are accurate and consistent' • IEC 61508-3, Table A.3 (3) 'Language subset' • IEC 62304, 5.5.3 - Software Unit acceptance criteria • ISO 26262-6, Table 1 (1b) 'Use of language subsets' • EN 50128, Table A.4 (11) 'Language Subset'
Last Changed	2018a

ID: Title	hisf_0017: Stateflow data object scoping																																																								
Examples	<p>Model Hierarchy</p> <ul style="list-style-type: none"> Simulink Root <ul style="list-style-type: none"> Base Workspace ex_hisf_0017_pass <ul style="list-style-type: none"> Model Workspace Configuration (Active) Embedded Coder Simulink Design Verifier results Chart 	<p>Contents of: ex_hisf_0017_pass/Chart (only)</p> <p>Column View: Stateflow Show Details 2 of 11 object(s)</p> <table border="1"> <thead> <tr> <th>Name</th> <th>Scope</th> <th>Port</th> <th>Resolve Signal</th> <th>Data Type</th> <th>Size</th> <th>Initial Value</th> <th>Compiled Ty</th> </tr> </thead> <tbody> <tr> <td>Input</td> <td>Input</td> <td>1</td> <td></td> <td>Inherit: Same as Si...</td> <td>-1</td> <td></td> <td>unknown</td> </tr> <tr> <td>x</td> <td>Local</td> <td></td> <td></td> <td>int32</td> <td>1</td> <td></td> <td>unknown</td> </tr> </tbody> </table>	Name	Scope	Port	Resolve Signal	Data Type	Size	Initial Value	Compiled Ty	Input	Input	1		Inherit: Same as Si...	-1		unknown	x	Local			int32	1		unknown																															
	Name	Scope	Port	Resolve Signal	Data Type	Size	Initial Value	Compiled Ty																																																	
	Input	Input	1		Inherit: Same as Si...	-1		unknown																																																	
x	Local			int32	1		unknown																																																		
<p>Recommended</p> <p>Model Hierarchy</p> <ul style="list-style-type: none"> Simulink Root <ul style="list-style-type: none"> Base Workspace ex_hisf_0017_warn <ul style="list-style-type: none"> Model Workspace Configuration (Active) Embedded Coder Simulink Design Verifier results Chart 	<p>Contents of: ex_hisf_0017_warn (only)</p> <p>Column View: Stateflow Show Details 7 of 8 object(s)</p> <table border="1"> <thead> <tr> <th>Name</th> <th>Scope</th> <th>Port</th> <th>Resolve Signal</th> <th>Data Type</th> <th>Size</th> <th>Initial Value</th> </tr> </thead> <tbody> <tr> <td>Model Workspace</td> <td></td> <td></td> <td></td> <td></td> <td></td> <td></td> </tr> <tr> <td>Configuration (Ac...</td> <td></td> <td></td> <td></td> <td></td> <td></td> <td></td> </tr> <tr> <td>Embedded Coder</td> <td></td> <td></td> <td></td> <td></td> <td></td> <td></td> </tr> <tr> <td>Simulink Design V...</td> <td></td> <td></td> <td></td> <td></td> <td></td> <td></td> </tr> <tr> <td>In1</td> <td></td> <td>1</td> <td></td> <td></td> <td></td> <td></td> </tr> <tr> <td>Chart</td> <td></td> <td></td> <td></td> <td></td> <td></td> <td></td> </tr> <tr> <td>x</td> <td>Local</td> <td></td> <td></td> <td>int32</td> <td>1</td> <td></td> </tr> </tbody> </table>	Name	Scope	Port	Resolve Signal	Data Type	Size	Initial Value	Model Workspace							Configuration (Ac...							Embedded Coder							Simulink Design V...							In1		1					Chart							x	Local			int32	1	
Name	Scope	Port	Resolve Signal	Data Type	Size	Initial Value																																																			
Model Workspace																																																									
Configuration (Ac...																																																									
Embedded Coder																																																									
Simulink Design V...																																																									
In1		1																																																							
Chart																																																									
x	Local			int32	1																																																				
<p>Not Recommended</p>																																																									

MATLAB Function and MATLAB Code Considerations

- “MATLAB Functions” on page 4-2
- “MATLAB Code” on page 4-12

MATLAB Functions

In this section...
“himl_0001: Usage of standardized MATLAB function headers” on page 4-2
“himl_0002: Strong data typing at MATLAB function boundaries” on page 4-3
“himl_0003: Limitation of MATLAB function complexity” on page 4-6
“himl_0005: Usage of global variables in MATLAB functions” on page 4-8

himl_0001: Usage of standardized MATLAB function headers

ID: Title	himl_0001: Usage of standardized MATLAB function headers
Description	When using MATLAB functions, use a standardized header to provide information about the purpose and use of the function.
Rationale	A standardized header improves the readability and documentation of MATLAB functions. The header should provide a function description and usage information.
References	<ul style="list-style-type: none"> DO-331, Section MB.6.3.4.e - Source code is traceable to low-level requirements
See Also	<ul style="list-style-type: none"> MathWorks Automotive Advisory Board (MAAB) guideline na_0025: MATLAB Function Header Orion GN&C: MATLAB and Simulink Standards, jh_0073: eML Header “MATLAB Function Block Editor”
Last Changed	R2016b
Examples	<p>A typical standardized function header includes:</p> <ul style="list-style-type: none"> Function name Description Inputs and outputs (if possible, include size and type) Assumptions and limitations Revision history

himl_0002: Strong data typing at MATLAB function boundaries

ID: Title	himl_0002: Strong data typing at MATLAB function boundaries
Description	<p>To support strong data typing at the interfaces of MATLAB functions, explicitly define the interface for input signals, output signals, and parameters, by setting:</p> <ul style="list-style-type: none"> • Complexity • Type
Rationale	<p>Defined interfaces:</p> <ul style="list-style-type: none"> • Allow consistency checking of interfaces. • Prevent unintended generation of different functions for different input and output types. • Simplify testing of functions by limiting the number of test cases.
Model Advisor Checks	<ul style="list-style-type: none"> • By Task > Modeling Standards for DO-178C/DO-331 > High-Integrity Systems > MATLAB > Check for MATLAB Function interfaces with inherited properties • By Task > Modeling Standards for IEC 61508 > High-Integrity Systems > MATLAB > Check for MATLAB Function interfaces with inherited properties • By Task > Modeling Standards for IEC 62304 > High-Integrity Systems > MATLAB > Check for MATLAB Function interfaces with inherited properties • By Task > Modeling Standards for ISO 26262 > High-Integrity Systems > MATLAB > Check for MATLAB Function interfaces with inherited properties • By Task > Modeling Standards for EN 50128 > High-Integrity Systems > MATLAB > Check for MATLAB Function interfaces with inherited properties <p>For DO-178C/DO-331 check details, see Check for MATLAB Function interfaces with inherited properties.</p> <p>For IEC 61508, IEC 62304, EN 50128, and ISO 26262 check details, see Check for MATLAB Function interfaces with inherited properties.</p>

ID: Title	himl_0002: Strong data typing at MATLAB function boundaries
References	<ul style="list-style-type: none">• IEC 61508-3, Table B.9 (6) - Fully defined interface• IEC 62304, 5.5.3 - Software Unit acceptance criteria• ISO 26262-6, Table 1 (1f) - Use of unambiguous graphical representation• EN 50128, Table A.1 (11) - Software Interface Specifications• DO-331, Section MB.6.3.2.b - Low-level requirements are accurate and consistent
See Also	<ul style="list-style-type: none">• MathWorks Automotive Advisory Board (MAAB) guideline na_0034: MATLAB Function block input/output settings• Orion GN&C: MATLAB and Simulink Standards, jh_0063: eML block input / output settings• “MATLAB Function Block Editor”
Last Changed	R2016a

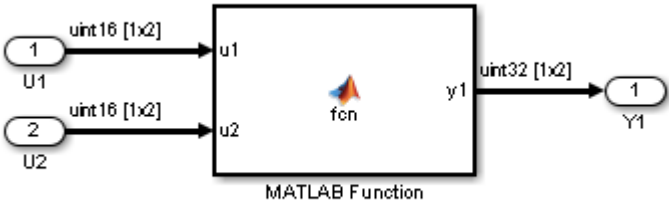
ID: Title	himl_0002: Strong data typing at MATLAB function boundaries
Examples	<p data-bbox="360 300 571 329">Recommended:</p> <p data-bbox="360 357 1305 418">In the “Ports and Data Manager”, specify the complexity and type of input u1 as follows:</p> <ul data-bbox="360 446 645 522" style="list-style-type: none"> <li data-bbox="360 446 645 475">• Complexity to Off <li data-bbox="360 486 645 515">• Type to uint16 <div data-bbox="368 552 1170 857" style="text-align: center;">  </div> <p data-bbox="360 892 630 921">Not Recommended:</p> <p data-bbox="360 949 1283 1010">In the “Ports and Data Manager”, do <i>not</i> specify the complexity and type of input u1 as follows:</p> <ul data-bbox="360 1038 912 1114" style="list-style-type: none"> <li data-bbox="360 1038 912 1067">• Complexity to Inherited <li data-bbox="360 1078 912 1107">• Type to Inherit: Same as Simulink. <p data-bbox="360 1168 1224 1229">Note To access the “Ports and Data Manager”, from the toolbar of the “MATLAB Function Block Editor”, select Edit Data.</p>

himl_0003: Limitation of MATLAB function complexity

ID: Title	himl_0003: Limitation of MATLAB function complexity											
Description	<p>When using MATLAB functions, limit the size and complexity of MATLAB code. The size and complexity of MATLAB functions is characterized by:</p> <ul style="list-style-type: none"> • Lines of code • Nested function levels • Cyclomatic complexity • Density of comments (ratio of comment lines to lines of code) 											
Note	<p>Size and complexity limits can vary across projects. Typical limits might be as described in this table:</p> <table border="1" data-bbox="363 720 1338 937"> <thead> <tr> <th data-bbox="363 720 798 760">Metric</th> <th data-bbox="798 720 1338 760">Limit</th> </tr> </thead> <tbody> <tr> <td data-bbox="363 760 798 807">Lines of code</td> <td data-bbox="798 760 1338 807">60 per MATLAB function</td> </tr> <tr> <td data-bbox="363 807 798 854">Nested function levels</td> <td data-bbox="798 807 1338 854">3^{1,2}</td> </tr> <tr> <td data-bbox="363 854 798 900">Cyclomatic complexity</td> <td data-bbox="798 854 1338 900">15</td> </tr> <tr> <td data-bbox="363 900 798 937">Density of comments</td> <td data-bbox="798 900 1338 937">0.2 comment lines per line of code</td> </tr> </tbody> </table> <p>¹Pure Wrappers to external functions are not counted as separate levels.</p> <p>²Standard MATLAB library functions do not count as separate levels.</p>		Metric	Limit	Lines of code	60 per MATLAB function	Nested function levels	3 ^{1,2}	Cyclomatic complexity	15	Density of comments	0.2 comment lines per line of code
Metric	Limit											
Lines of code	60 per MATLAB function											
Nested function levels	3 ^{1,2}											
Cyclomatic complexity	15											
Density of comments	0.2 comment lines per line of code											
Rationale	<ul style="list-style-type: none"> • Readability • Comprehension • Traceability • Maintainability • Testability 											

ID: Title	himl_0003: Limitation of MATLAB function complexity
Model Advisor Checks	<ul style="list-style-type: none"> • By Task > Modeling Standards for DO-178C/DO-331 > High-Integrity Systems > MATLAB > Check MATLAB Function metrics • By Task > Modeling Standards for IEC 61508 > High-Integrity Systems > MATLAB > Check MATLAB Function metrics • By Task > Modeling Standards for IEC 62304 > High-Integrity Systems > MATLAB > Check MATLAB Function metrics • By Task > Modeling Standards for ISO 26262 > High-Integrity Systems > MATLAB > Check MATLAB Function metrics • By Task > Modeling Standards for EN 50128 > High-Integrity Systems > MATLAB > Check MATLAB Function metrics <p>For DO-178C/DO-331 check details, see Check MATLAB Function metrics.</p> <p>For IEC 61508, IEC 62304, EN 50128, and ISO 26262 check details, see Check MATLAB Function metrics.</p>
References	<ul style="list-style-type: none"> • IEC 61508-3, Table B.9 (6) - Fully defined interface • IEC 62304, 5.5.3 - Software Unit acceptance criteria • ISO 26262-6, Table 1 (1f) - Use of unambiguous graphical representation • EN 50128, Table A.1(11) - Software Interface Specifications • DO-331, Sections MB.6.3.1.e - High-level requirements conform to standards • DO-331, Sections MB.6.3.2.e - Low-level requirements conform to standards
See Also	<ul style="list-style-type: none"> • MathWorks Automotive Advisory Board (MAAB) guideline na_0016: Source lines of MATLAB Functions • MathWorks Automotive Advisory Board (MAAB) guideline na_0017: Number of called function levels • MathWorks Automotive Advisory Board (MAAB) guideline na_0018: Number of nested if/else and case statement • Orion GN&C: MATLAB and Simulink Standards, jh_0084: eML Comments • "MATLAB Function Block Editor"
Last Changed	R2016a

himl_0005: Usage of global variables in MATLAB functions

ID: Title	himl_0005: Usage of global variables in MATLAB functions
Description	Avoid using global variables in MATLAB functions. To access shared data, use signal lines or persistent data.
Notes	Using global data in MATLAB code requires the definition of Data Store Memory blocks or Custom Storage class objects. If the read and write access order is not specified correctly, usage of this type of storage can lead to unexpected results.
Rationale	<ul style="list-style-type: none"> • Readability • Maintainability • Deterministic Behavior
Model Advisor Checks	<ul style="list-style-type: none"> • By Task > Modeling Standards for DO-178C/DO-331 > High-Integrity Systems > MATLAB > Check MATLAB code for global variables • By Task > Modeling Standards for IEC 61508 > High-Integrity Systems > MATLAB > Check MATLAB code for global variables • By Task > Modeling Standards for IEC 62304 > High-Integrity Systems > MATLAB > Check MATLAB code for global variables • By Task > Modeling Standards for EN 50128 > High-Integrity Systems > MATLAB > Check MATLAB code for global variables • By Task > Modeling Standards for ISO 26262 > High-Integrity Systems > MATLAB > Check MATLAB code for global variables <p>For DO-178C/DO-331 check details, see Check MATLAB code for global variables.</p> <p>For IEC 61508, IEC 62304, EN 50128, and ISO 26262 check details, see Check MATLAB code for global variables.</p>
References	<ul style="list-style-type: none"> • IEC 61508-3, Table A.3 (3) 'Language subset' • IEC 62304, 5.5.3 - Software Unit acceptance criteria • ISO 26262-6, Table 1(b) 'Use of language subsets' • EN 50128, Table A.4 (11) 'Language Subset' • DO-331, Section MB.6.3.3.b 'Consistency'

ID: Title	himl_0005: Usage of global variables in MATLAB functions
See Also	<ul style="list-style-type: none">• na_0024: Global Variables• “hisl_0013: Usage of data store blocks” on page 2-39
Last Changed	R2016a

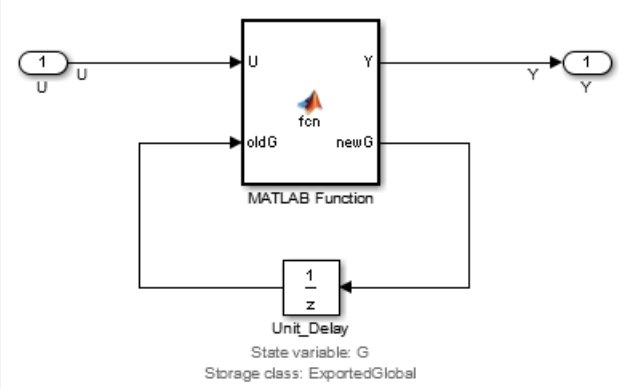
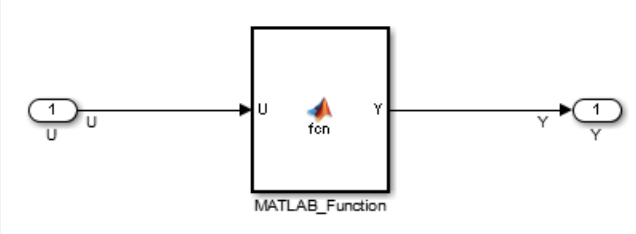
ID: Title	himl_0005: Usage of global variables in MATLAB functions
Examples	<ul style="list-style-type: none"> Recommended <pre data-bbox="427 361 756 529"> function [Y,newG] = ... fcn(U,oldG) %#codegen Y = oldG * U; newG = oldG + 1; end </pre>  Recommended <pre data-bbox="427 1038 712 1206"> function Y = fcn(U) %#codegen persistent G; if isempty(G) G = 1; end </pre>  Not Recommended

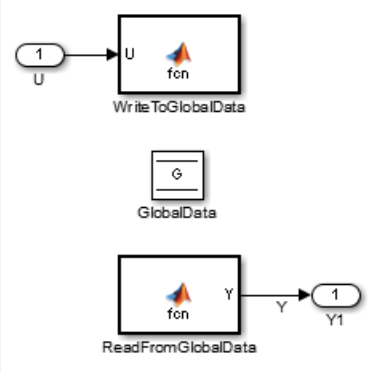
ID: Title	himl_0005: Usage of global variables in MATLAB functions
	<p>Write to global data function:</p> <pre data-bbox="427 352 639 493">function fcn(U) %#codegen global G; G = U; End</pre> <p>Read from global data function:</p> <pre data-bbox="427 579 658 720">function Y = fcn %#codegen global G; Y = G; end</pre>  <p>The diagram illustrates the flow of data between MATLAB functions and global data. It consists of three main components:</p> <ul style="list-style-type: none">WriteToGlobalData: A block that takes an input signal 'U' (represented by a rounded rectangle with '1' and 'U') and outputs to a 'GlobalData' block. The block is labeled 'fcn' and 'WriteToGlobalData'.GlobalData: A block representing the global data store, labeled 'GlobalData'.ReadFromGlobalData: A block that reads from the 'GlobalData' block and outputs a signal 'Y' (represented by a rounded rectangle with '1' and 'Y1'). The block is labeled 'fcn' and 'ReadFromGlobalData'.

MATLAB Code

In this section...
“himl_0004: MATLAB Code Analyzer recommendations for code generation” on page 4-12
“himl_0006: MATLAB code if / elseif / else patterns” on page 4-16
“himl_0007: MATLAB code switch / case / otherwise patterns” on page 4-18
“himl_0008: MATLAB code relational operator data types” on page 4-20
“himl_0009: MATLAB code with equal / not equal relational operators” on page 4-21
“himl_0010: MATLAB code with logical operators and functions” on page 4-22

himl_0004: MATLAB Code Analyzer recommendations for code generation

ID: Title	himl_0004: MATLAB Code Analyzer recommendations for code generation	
Description	When using MATLAB code:	
	A	To activate MATLAB Code Analyzer messages for code generations, use the <code>%#codegen</code> directive in external MATLAB functions.
	B	Review the MATLAB Code Analyzer messages. Either: <ul style="list-style-type: none"> • Implement the recommendations or • Justify not following the recommendations with <code>%#ok<message-ID(S)></code> directives in the MATLAB function. Do not use <code>%#ok</code> without specific message-IDs.
Notes	The MATLAB Code Analyzer messages provide identifies potential errors, problems, and opportunities for improvement in the code.	
Rationale	A	In external MATLAB functions, the <code>%#codegen</code> directive activates MATLAB Code Analyzer messages for code generation.

ID: Title	himl_0004: MATLAB Code Analyzer recommendations for code generation	
	B	<ul style="list-style-type: none"> • Following MATLAB Code Analyzer recommendations helps to: <ul style="list-style-type: none"> • Generate efficient code. • Follow best code generation practices • Avoid using MATLAB features not supported for code generation. • Avoid code patterns which potentially influence safety. • Not following MATLAB Code Analyzer recommendations are justified with message id (e.g. %#ok<NOPRT>. <p>In the MATLAB function, using %#ok without a message id justifies the full line, potentially hiding issues.</p>
Model Advisor Checks	<ul style="list-style-type: none"> • By Task > Modeling Standards for DO-178C/DO-331 > High-Integrity Systems > MATLAB > Check MATLAB Code Analyzer messages • By Task > Modeling Standards for IEC 61508 > High-Integrity Systems > MATLAB > Check MATLAB Code Analyzer messages • By Task > Modeling Standards for IEC 62304 > High-Integrity Systems > MATLAB > Check MATLAB Code Analyzer messages • By Task > Modeling Standards for EN 50128 > High-Integrity Systems > MATLAB > Check MATLAB Code Analyzer messages • By Task > Modeling Standards for ISO 26262 > High-Integrity Systems > MATLAB > Check MATLAB Code Analyzer messages <p>For DO-178C/DO-331 check details, see Check MATLAB Code Analyzer messages.</p> <p>For IEC 61508, IEC 62304, EN 50128, and ISO 26262 check details, see Check MATLAB Code Analyzer messages.</p>	

ID: Title	himl_0004: MATLAB Code Analyzer recommendations for code generation
References	<ul style="list-style-type: none"> • IEC 61508-3, Table A.3 (3) 'Language subset' IEC 61508-3, Table A.4 (3) 'Defensive programming' IEC 61508-3, Table A.4 (5) 'Design and coding standards' • IEC 62304, 5.5.3 - Software Unit acceptance criteria • ISO 26262-6, Table 1 (1b) 'Use of language subsets' ISO 26262-6, Table 1 (1d) 'Use of defensive implementation techniques' ISO 26262-6, Table 1 (1e) 'Use of established design principles' ISO 26262-6, Table 1 (1f) 'Use of unambiguous graphical representation' ISO 26262-6, Table 1 (1g) 'Use of style guide' ISO 26262-6, Table 1 (1h) 'Use of naming conventions' • EN 50128, Table A.4 (11) 'Language Subset' EN 50128, Table A.3 (1) 'Defensive Programming' EN 50128, Table A.12 (1) 'Coding Standard' EN 50128, Table A.12 (2) 'Coding Style Guide' • DO-331, Section MB.6.3.1.b 'Accuracy and consistency' DO-331, Section MB.6.3.2.b 'Accuracy and consistency'
See Also	"Check Code for Errors and Warnings" (MATLAB)
Last Changed	R2016a

ID: Title	himl_0004: MATLAB Code Analyzer recommendations for code generation
Examples	<p>Recommended</p> <ul style="list-style-type: none"> Activate MATLAB Code Analyzer messages for code generations: <pre> %#codegen function y = function(u) y = inc_u(u)); end function yy = inc_u(uu) yy = uu + 1; end </pre> Justify missing ; and value assigned might be unused: <pre> y = 2*u %#ok<NOPRT,NAGSU> output for debugging ... y = 3*u; </pre> If output is not desired and assigned value is unused, remove the line <code>y = 2*u ...</code>: <pre> y = 3*u; </pre> <p>Not Recommended</p> <ul style="list-style-type: none"> External MATLAB file used in Simulink with missing <code>%#codegen</code> directive: <pre> function y = function(u) % nested functions can't be used for code generation function yy = inc_u(uu) yy = uu + 1; end y = inc_u(u)); end </pre> All messages in line are justified by using <code>%#ok</code> without a message ID: <pre> % missing ';' and the value might be unused y = 2*u %#ok ... y = 3*u; </pre> No justification:

ID: Title	himl_0004: MATLAB Code Analyzer recommendations for code generation
	% missing justification for missing ';' and unnecessary '['..]' y= [2*u]

himl_0006: MATLAB code if / elseif / else patterns

ID: Title	himl_0006: MATLAB code if / elseif / else patterns
Description	For MATLAB code with if / elseif/ else constructs, terminate the constructs with an else statement that includes at least a meaningful comment. A final else statement is not required if there is no elseif.
Rationale	<ul style="list-style-type: none"> • Defensive programming • Readability • Traceability
References	<ul style="list-style-type: none"> • IEC 61508-3, Table A.3 (3) 'Language subset' • IEC 61508-3, Table A.4 (3) 'Defensive programming' • IEC 62304, 5.5.3 - Software Unit acceptance criteria • ISO 26262-6, Table 1(b) 'Use of language subsets' • ISO 26262-6, Table 1(d) 'Use of defensive implementation techniques' • EN 50128, Table A.4 (11) 'Language Subset' • EN 50128, Table A.3 (1) 'Defensive Programming' • DO-331, Section MB.6.3.1.e 'Conformance to standards' • DO-331, Section MB.6.3.2.e 'Conformance to standards' • DO-331, Section MB.6.3.3.e 'Conformance to standards'
See Also	<ul style="list-style-type: none"> • "hisl_0010: Usage of If blocks and If Action Subsystem blocks" on page 2-27
Last Changed	R2016a

ID: Title	himl_0006: MATLAB code if / elseif / else patterns
Examples	<p>Recommended</p> <ul style="list-style-type: none">• <pre>if u > 0 y = 1; end</pre>• <pre>if u > 0 y = 1; elseif u < 0 y = -1; else y = 0; end</pre>• <pre>y = 0; if u > 0 y = 1; elseif u < 0 y = -1; else % handled before if end</pre> <p>Not Recommended</p> <ul style="list-style-type: none">• <pre>% empty else y = 0; if u > 0 y = 1; elseif u < 0 y = -1; else end</pre>• <pre>% missing else y = 0; if u > 0 y = 1; elseif u < 0 y = -1; end</pre>

himl_0007: MATLAB code switch / case / otherwise patterns

ID: Title	himl_0007: MATLAB code switch / case / otherwise patterns
Description	<p>For MATLAB code with <code>switch</code> statements, include:</p> <ul style="list-style-type: none"> • At least two <code>case</code> statements. • An <code>otherwise</code> statement that at least includes a meaningful comment.
Note	If there is only one <code>case</code> and one <code>otherwise</code> statement, consider using an <code>if / else</code> statement.
Rationale	<ul style="list-style-type: none"> • Defensive programming • Readability • Traceability
References	<ul style="list-style-type: none"> • IEC 61508-3, Table A.3 (3) 'Language subset' • IEC 61508-3, Table A.4 (3) 'Defensive programming' • IEC 62304, 5.5.3 - Software Unit acceptance criteria • ISO 26262-6, Table 1(b) 'Use of language subsets' • ISO 26262-6, Table 1(d) 'Use of defensive implementation techniques' • EN 50128, Table A.4 (11) 'Language Subset' • EN 50128, Table A.3 (1) 'Defensive Programming' • DO-331, Section MB.6.3.1.e 'Conformance to standards' • DO-331, Section MB.6.3.2.e 'Conformance to standards' • DO-331, Section MB.6.3.3.e 'Conformance to standards' • MISRA C:2012, Rule 16.4
See Also	<ul style="list-style-type: none"> • na_0022: Recommended patterns for Switch/Case statements • "hisl_0011: Usage of Switch Case blocks and Action Subsystem blocks" on page 2-30
Last Changed	R2016a

ID: Title	himl_0007: MATLAB code switch / case / otherwise patterns
Examples	<p>Recommended</p> <ul style="list-style-type: none"> • <pre>switch u case 1 y = 3; case 3 y = 1; otherwise y = 1; end</pre> • <pre>y = 0; switch u case 1 y = 3; case 3 y = 1; otherwise % handled before switch end</pre> <p>Not Recommended</p> <ul style="list-style-type: none"> • <pre>% no case statements switch u otherwise y = 1; end</pre> • <pre>% empty otherwise statement switch u case 1 y = 3; case 3 y = 1; otherwise end</pre> • <pre>% no otherwise statement switch u case 1 y = 3; end</pre>

himl_0008: MATLAB code relational operator data types

ID: Title	himl_0008: MATLAB code relational operator data types
Description	For MATLAB code with relational operators, use the same data type for the left and right operands.
Note	If the two operands have different data types, MATLAB will promote both operands to a common data type. This can lead to unexpected results.
Rationale	<ul style="list-style-type: none"> • Prevent implicit casts • Prevent unexpected results
References	<ul style="list-style-type: none"> • IEC 61508-3, Table A.3 (2) 'Strongly typed programming language' • IEC 61508-3, Table A.3 (3) 'Language subset' • IEC 62304, 5.5.3 - Software Unit acceptance criteria • ISO 26262-6, Table 1(c) 'Enforcement of strong typing' • ISO 26262-6, Table 1(b) 'Use of language subsets' • EN 50128, Table A.4 (8) 'Strongly Typed Programming Language' • EN 50128, Table A.4 (11) 'Language Subset' • DO-331, Section MB.6.3.1.g 'Algorithms are accurate' • DO-331, Section MB.6.3.2.g 'Algorithms are accurate'
See Also	<ul style="list-style-type: none"> • "hisl_0016: Usage of blocks that compute relational operators" on page 2-50 • "hisl_0017: Usage of blocks that compute relational operators (2)" on page 2-52
Last Changed	R2016a
Examples	<p>Recommended</p> <ul style="list-style-type: none"> • <code>myBool == true</code> • <code>myInt8 == int8(1)</code> <p>Not Recommended</p> <ul style="list-style-type: none"> • <code>myBool == 1</code> • <code>myInt8 == true</code> • <code>myInt8 == 1</code> • <code>myInt8 == int16(1)</code> • <code>myEnum1.EnumVal == int32(1)</code>

himl_0009: MATLAB code with equal / not equal relational operators

ID: Title	himl_0009: MATLAB code with equal / not equal relational operators
Description	<p>For MATLAB code with equal or not equal relational operators, avoid using the following data types:</p> <ul style="list-style-type: none"> • Single • Double • Types derived from single or double data types
Note	<p>Consider the following code fragments:</p> <pre>1 sqrt(2)^2 == 2 2 sqrt(2^2) == 2</pre> <p>Mathematically, both fragments are true. However, because of floating point rounding effects, the results are:</p> <pre>1 false 2 true</pre>
Rationale	<ul style="list-style-type: none"> • Prevent unexpected results
References	<ul style="list-style-type: none"> • IEC 61508-3, Table A.3 (3) 'Language subset' • IEC 61508-3, Table A.4 (3) 'Defensive programming' • IEC 62304, 5.5.3 - Software Unit acceptance criteria • ISO 26262-6, Table 1 (1b) 'Use of language subsets' • ISO 26262-6, Table 1 (1d) 'Use of defensive implementation techniques' • EN 50128, Table A.4 (11) 'Language Subset' • EN 50128, Table A.3 (1) 'Defensive Programming' • DO-331, Section MB.6.3.1.g 'Algorithms are accurate' • EN 50128, MB.6.3.2.g ' 'Defensive Programming' • MISRA C:2012, Dir 1.1
See Also	<ul style="list-style-type: none"> • jc_0481: Use of hard equality comparisons for floating point numbers in Stateflow • "himl_0016: Usage of blocks that compute relational operators" on page 2-50

ID: Title	himl_0009: MATLAB code with equal / not equal relational operators
Last Changed	R2016a
Examples	<p>Recommended</p> <ul style="list-style-type: none"> • <code>myDouble >= 0.99 && myDouble <= 1.01; % test range</code> <p>Not Recommended</p> <ul style="list-style-type: none"> • <code>myDouble == 1.0</code> • <code>mySingle ~= 15.0</code>

himl_0010: MATLAB code with logical operators and functions

ID: Title	himl_0010: MATLAB code with logical operators and functions
Description	For logical operators and logical functions in MATLAB code, use logical data types
Notes	<p>Logical operators: <code>&&</code>, <code> </code>, <code>~</code></p> <p>Logical functions: <code>and</code>, <code>or</code>, <code>not</code>, <code>xor</code></p>
Rationale	<ul style="list-style-type: none"> • Prevent unexpected results
References	<ul style="list-style-type: none"> • IEC 61508-3, Table A.3 (2) 'Strongly typed programming language' • IEC 61508-3, Table A.3 (3) 'Language subset' • IEC 62304, 5.5.3 - Software Unit acceptance criteria • ISO 26262-6, Table 1(c) 'Enforcement of strong typing' • ISO 26262-6, Table 1(b) 'Use of language subsets' • EN 50128, Table A.4 (8) 'Strongly Typed Programming Language' • EN 50128, Table A.4 (11) 'Language Subset' • DO-331, Section MB.6.3.1.g 'Algorithms are accurate' • DO-331, Section MB.6.3.2.g 'Algorithms are accurate'
Last Changed	R2016a

ID: Title	himl_0010: MATLAB code with logical operators and functions
Examples	<p data-bbox="387 300 587 326">Recommended</p> <ul data-bbox="387 357 872 440" style="list-style-type: none"><li data-bbox="387 357 872 440">• ~myLogical (myInt8 > int8(4)) && myLogical xor(myLogical1,myLogical2) <p data-bbox="387 472 642 498">Not Recommended</p> <ul data-bbox="387 529 687 578" style="list-style-type: none"><li data-bbox="387 529 687 578">• ~myInt8 myInt8 && myDouble

Configuration Parameter Considerations

- “Solver” on page 5-2
- “Math and Data Types” on page 5-7
- “Diagnostics” on page 5-9
- “Model Referencing” on page 5-37
- “Code Generation” on page 5-39

Solver

In this section...
“hisl_0040: Configuration Parameters > Solver > Simulation time” on page 5-2
“hisl_0041: Configuration Parameters > Solver > Solver options” on page 5-4
“hisl_0042: Configuration Parameters > Solver > Tasking and sample time options” on page 5-5

hisl_0040: Configuration Parameters > Solver > Simulation time

ID: Title	hisl_0040: Configuration Parameters > Solver > Simulation time	
Description	For models used to develop high-integrity systems, in the Configuration Parameters dialog box, on the Solver pane, set parameters for simulation time as follows:	
	A	Start time to 0.0.
	B	Stop time to a positive value that is less than the value of Application lifespan (days) .
Note	Simulink allows nonzero start times for simulation. However, production code generation requires a zero start time.	
	By default, Application lifespan (days) is auto. If you do not change this setting, any positive value for Stop time is valid.	
	You specify Stop time in seconds and Application lifespan (days) is in days.	
Rationale	A	Generate code that is valid for production code generation.

ID: Title	hisl_0040: Configuration Parameters > Solver > Simulation time
Model Advisor Checks	<ul style="list-style-type: none"> • By Task > Modeling Standards for DO-178C/DO-331 > High-Integrity Systems > Configuration > Check safety-related solver settings for simulation time • By Task > Modeling Standards for IEC 61508 > High-Integrity Systems > Configuration > Check safety-related solver settings for simulation time • By Task > Modeling Standards for IEC 62304 > High-Integrity Systems > Configuration > Check safety-related solver settings for simulation time • By Task > Modeling Standards for EN 50128 > High-Integrity Systems > Configuration > Check safety-related solver settings for simulation time • By Task > Modeling Standards for ISO 26262 > High-Integrity Systems > Configuration > Check safety-related solver settings for simulation time <p>For DO-178C/DO-331 check details, see Check safety-related solver settings for simulation time.</p> <p>For IEC 61508, IEC 62304, EN 50128, and ISO 26262 check details, see Check safety-related solver settings for simulation time.</p>
References	<ul style="list-style-type: none"> • DO-331 Section MB.6.3.1.g—Algorithms are accurate • DO-331 Section MB.6.3.2.g—Algorithms are accurate • IEC 61508-3, Table A.3 (3) 'Language subset' • IEC 62304, 5.5.3 - Software Unit acceptance criteria • ISO 26262-6, Table 1 (1b) 'Use of language subsets' • EN 50128, Table A.4 (11) 'Language Subset'
See Also	<ul style="list-style-type: none"> • “hisl_0048: Configuration Parameters > Math and Data Types > Application lifespan (days)” on page 5-7 • Solver Pane section of the Simulink documentation
Last Changed	R2017b

hisl_0041: Configuration Parameters > Solver > Solver options

ID: Title	hisl_0041: Configuration Parameters > Solver > Solver options	
Description	For models used to develop high-integrity systems, in the Configuration Parameters dialog box, on the Solver pane, set parameters for solvers as follows:	
	A	Type to Fixed-step.
	B	Solver to discrete (no continuous states).
Note	Generating code for production requires a fixed-step, discrete solver.	
Rationale	A, B	Generate code that is valid for production code generation.
Model Advisor Checks	<ul style="list-style-type: none"> • By Task > Modeling Standards for DO-178C/DO-331 > High-Integrity Systems > Configuration > Check safety-related solver settings for solver options • By Task > Modeling Standards for IEC 61508 > High-Integrity Systems > Configuration > Check safety-related solver settings for solver options • By Task > Modeling Standards for IEC 62304 > High-Integrity Systems > Configuration > Check safety-related solver settings for solver options • By Task > Modeling Standards for EN 50128 > High-Integrity Systems > Configuration > Check safety-related solver settings for solver options • By Task > Modeling Standards for ISO 26262 > High-Integrity Systems > Configuration > Check safety-related solver settings for solver options <p data-bbox="373 1204 1335 1263">For DO-178C/DO-331 check details, see Check safety-related solver settings for solver options.</p> <p data-bbox="373 1295 1335 1354">For IEC 61508, IEC 62304, EN 50128, and ISO 26262 check details, see Check safety-related solver settings for solver options.</p>	

ID: Title	hisl_0041: Configuration Parameters > Solver > Solver options
References	<ul style="list-style-type: none"> • DO-331 Section MB.6.3.1.g—Algorithms are accurate • DO-331 Section MB.6.3.2.g—Algorithms are accurate • IEC 61508-3, Table A.3 (3) 'Language subset' • IEC 62304, 5.5.3 - Software Unit acceptance criteria • ISO 26262-6, Table 1 (1b) 'Use of language subsets' • EN 50128, Table A.4 (11) 'Language Subset'
See Also	"Solver Pane" in the Simulink documentation
Last Changed	R2017b

hisl_0042: Configuration Parameters > Solver > Tasking and sample time options

ID: Title	hisl_0042: Configuration Parameters > Solver > Tasking and sample time options
Description	For models used to develop high-integrity systems, in the Configuration Parameters dialog box, on the Solver pane, clear Automatically handle rate transition for data transfer .
Notes	<p>Selecting the Automatically handle rate transition for data transfer check box might result in inserting rate transition code without a corresponding model construct. This might impede establishing full traceability or showing that unintended functions are not introduced.</p> <p>You can select or clear the Higher priority value indicates higher task priority check box . Selecting this check box determines whether the priority for Sample time properties uses the lowest values as highest priority, or the highest values as highest priority.</p>
Rationale	Support fully specified models and unambiguous code.

ID: Title	hisl_0042: Configuration Parameters > Solver > Tasking and sample time options
Model Advisor Checks	<ul style="list-style-type: none"> • By Task > Modeling Standards for DO-178C/DO-331 > High-Integrity Systems > Configuration > Check safety-related solver settings for tasking and sample-time • By Task > Modeling Standards for IEC 61508 > High-Integrity Systems > Configuration > Check safety-related solver settings for tasking and sample-time • By Task > Modeling Standards for IEC 62304 > High-Integrity Systems > Configuration > Check safety-related solver settings for tasking and sample-time • By Task > Modeling Standards for EN 50128 > High-Integrity Systems > Configuration > Check safety-related solver settings for tasking and sample-time • By Task > Modeling Standards for ISO 26262 > High-Integrity Systems > Configuration > Check safety-related solver settings for tasking and sample-time <p>For DO-178C/DO-331 check details, see Check safety-related solver settings for tasking and sample-time.</p> <p>For IEC 61508, IEC 62304, EN 50128, and ISO 26262 check details, see Check safety-related solver settings for tasking and sample-time.</p>
References	<ul style="list-style-type: none"> • DO-331, Section MB.6.3.4.e 'Source code is traceable to low-level requirements' • IEC 61508-3, Table A.3 (3) 'Language subset' • IEC 62304, 5.5.3 - Software Unit acceptance criteria • ISO 26262-6, Table 1 (1b) 'Use of language subsets' • EN 50128, Table A.4 (11) 'Language Subset'
See Also	"Solver Pane" in the Simulink documentation
Last Changed	R2018a

Math and Data Types

hisl_0048: Configuration Parameters > Math and Data Types > Application lifespan (days)

ID: Title	hisl_0048: Configuration Parameters > Math and Data Types > Application lifespan (days)
Description	To support the robustness of systems that run continuously, set Configuration Parameter Application lifespan (days) to <code>inf</code> .
Notes	Embedded applications might run continuously. Do not assume a limited lifespan for timers and counters. When you set Application lifespan (days) to <code>inf</code> , the simulation time is less than the application lifespan.
Rationale	Support robustness of systems that run continuously.
Model Advisor Checks	<ul style="list-style-type: none"> • By Task > Modeling Standards for DO-178C/DO-331 > High-Integrity Systems > Configuration > Check safety-related optimization settings • By Task > Modeling Standards for IEC 61508 > High-Integrity Systems > Configuration > Check safety-related optimization settings • By Task > Modeling Standards for IEC 62304 > High-Integrity Systems > Configuration > Check safety-related optimization settings • By Task > Modeling Standards for EN 50128 > High-Integrity Systems > Configuration > Check safety-related optimization settings • By Task > Modeling Standards for ISO 26262 > High-Integrity Systems > Configuration > Check safety-related optimization settings <p>For DO-178C/DO-331 check details, see Check safety-related optimization settings.</p> <p>For IEC 61508, IEC 62304, EN 50128, and ISO 26262 check details, see Check safety-related optimization settings.</p>

ID: Title	hisl_0048: Configuration Parameters > Math and Data Types > Application lifespan (days)
References	<ul style="list-style-type: none">• DO-331, Section MB.6.3.1.g 'Algorithms are accurate'• DO-331, Section MB.6.3.2.g 'Algorithms are accurate'• IEC 61508-3, Table A.4 (3) 'Defensive Programming'• IEC 62304, 5.5.3 - Software Unit acceptance criteria• ISO 26262-6, Table 1 (1d) 'Use of defensive implementation techniques'• EN 50128, Table A.3 (1) 'Defensive Programming'
See Also	<ul style="list-style-type: none">• "Application lifespan (days)" in the Simulink documentation• "hisl_0040: Configuration Parameters > Solver > Simulation time" on page 5-2
Last Changed	R2018a

Diagnostics

In this section...

"hisl_0036: Configuration Parameters > Diagnostics > Saving" on page 5-10

"hisl_0043: Configuration Parameters > Diagnostics > Solver" on page 5-11

"hisl_0044: Configuration Parameters > Diagnostics > Sample Time" on page 5-14

"hisl_0301: Configuration Parameters > Diagnostics > Compatibility" on page 5-17

"hisl_0302: Configuration Parameters > Diagnostics > Data Validity > Parameters" on page 5-19

"hisl_0303: Configuration Parameters > Diagnostics > Merge block" on page 5-20

"hisl_0304: Configuration Parameters > Diagnostics > Model initialization" on page 5-22

"hisl_0305: Configuration Parameters > Diagnostics > Debugging" on page 5-23

"hisl_0306: Configuration Parameters > Diagnostics > Connectivity > Signals" on page 5-25

"hisl_0307: Configuration Parameters > Diagnostics > Connectivity > Buses" on page 5-26

"hisl_0308: Configuration Parameters > Diagnostics > Connectivity > Function calls" on page 5-28

"hisl_0309: Configuration Parameters > Diagnostics > Type Conversion" on page 5-29

"hisl_0310: Configuration Parameters > Diagnostics > Model Referencing" on page 5-31

"hisl_0311: Configuration Parameters > Diagnostics > Stateflow" on page 5-32

"hisl_0314: Configuration Parameters > Diagnostics > Data Validity > Signals" on page 5-34

hisl_0036: Configuration Parameters > Diagnostics > Saving

ID: Title	hisl_0036: Configuration Parameters > Diagnostics > Saving
Description	<p>For models used to develop high-integrity systems, in the Configuration Parameters dialog box, set these parameters:</p> <ul style="list-style-type: none"> • Block diagram contains disabled library links to error • Block diagram contains parameterized library links to error
Rationale	Prevent unexpected results.
Model Advisor Checks	<ul style="list-style-type: none"> • By Task > Modeling Standards for DO-178C/DO-331 > High-Integrity Systems > Configuration > Check safety-related diagnostic settings for saving • By Task > Modeling Standards for IEC 61508 > High-Integrity Systems > Configuration > Check safety-related diagnostic settings for saving • By Task > Modeling Standards for IEC 62304 > High-Integrity Systems > Configuration > Check safety-related diagnostic settings for saving • By Task > Modeling Standards for EN 50128 > High-Integrity Systems > Configuration > Check safety-related diagnostic settings for saving • By Task > Modeling Standards for ISO 26262 > High-Integrity Systems > Configuration > Check safety-related diagnostic settings for saving <p>For DO-178C/DO-331 check details, see Check safety-related diagnostic settings for saving.</p> <p>For IEC 61508, IEC 62304, EN 50128, and ISO 26262 check details, see Check safety-related diagnostic settings for saving.</p>
References	<ul style="list-style-type: none"> • DO-331, Section MB.6.3.3.b 'Software architecture is consistent' • IEC 61508-3, Table A.3 (3) 'Language subset' • IEC 62304, 5.5.3 - Software Unit acceptance criteria • ISO 26262-6, Table 1 (1b) 'Use of language subsets' • ISO 26262-6, Table 1 (1f) 'Use of unambiguous graphical representation' • EN 50128, Table A.4 (11) 'Language Subset'
Last Changed	R2017b

hisl_0043: Configuration Parameters > Diagnostics > Solver

ID: Title	hisl_0043: Configuration Parameters > Diagnostics > Solver
Description	<p>For models used to develop high-integrity systems, in the Configuration Parameters dialog box, on the Diagnostics pane, set the Solver parameters as follows:</p> <ul style="list-style-type: none">• Algebraic loop to error.• Minimize algebraic loop to error.• Automatic solver parameter selection to error.• State name clash to warning.• Block priority violation to error if you are using block priorities.

ID: Title	hisl_0043: Configuration Parameters > Diagnostics > Solver	
Note	Enabling diagnostics pertaining to the solver provides information to detect violations of other guidelines.	
	If Diagnostic Parameter...	Is Not Set As Indicated, Then ...
	Algebraic loop	Automatic breakage of algebraic loops can go undetected and might result in unpredictable block order execution.
	Minimize algebraic loop	Automatic breakage of algebraic loops can go undetected and might result in unpredictable block order execution.
	Block priority violation	Block execution order can include undetected conflicts that might result in unpredictable block order execution.
	Unspecified inheritability of sample times	An S-function that is not explicitly set to inherit sample time can go undetected and result in unpredictable behavior.
	Automatic solver parameter selection	An automatic change to the solver, step size, or simulation stop time can go undetected and might the operation of generated code.
	State name clash	A name being used for more than one state might go undetected.
Rationale	<p>You can set the following diagnostic parameters to any value:</p> <ul style="list-style-type: none"> Min step size violation Consecutive zero crossings violation Solver data inconsistency Extraneous discrete derivative signals <p>Support generation of robust and unambiguous code.</p>	

ID: Title	hisl_0043: Configuration Parameters > Diagnostics > Solver
Model Advisor Checks	<ul style="list-style-type: none"> • By Task > Modeling Standards for DO-178C/DO-331 > High-Integrity Systems > Configuration > Check safety-related diagnostic settings for solvers • By Task > Modeling Standards for IEC 61508 > High-Integrity Systems > Configuration > Check safety-related diagnostic settings for solvers • By Task > Modeling Standards for IEC 62304 > High-Integrity Systems > Configuration > Check safety-related diagnostic settings for solvers • By Task > Modeling Standards for EN 50128 > High-Integrity Systems > Configuration > Check safety-related diagnostic settings for solvers • By Task > Modeling Standards for ISO 26262 > High-Integrity Systems > Configuration > Check safety-related diagnostic settings for solvers <p>For DO-178C/DO-331 check details, see Check safety-related diagnostic settings for solvers.</p> <p>For IEC 61508, IEC 62304, EN 50128, and ISO 26262 check details, see Check safety-related diagnostic settings for solvers.</p>
References	<ul style="list-style-type: none"> • IEC 61508-3, Table A.3 (3) 'Language subset' • IEC 62304, 5.5.3 - Software Unit acceptance criteria • ISO 26262-6, Table 1 (1b) 'Use of language subsets' • EN 50128, Table A.4 (11) 'Language Subset' • DO-331, MB.6.3.3.e 'Software architecture conforms to standards'
See Also	<ul style="list-style-type: none"> • "Model Configuration Parameters: Diagnostics" in the Simulink documentation • jc_0021: Model diagnostic settings in the Simulink documentation
Last Changed	R2017b

hisl_0044: Configuration Parameters > Diagnostics > Sample Time

ID: Title	hisl_0044: Configuration Parameters > Diagnostics > Sample Time
Description	<p>For models used to develop high-integrity systems, in the Configuration Parameters dialog box, on the Diagnostics > Sample Time pane, set the following Sample Time parameters to error:</p> <ul style="list-style-type: none">• Source block specifies -1 sample time• Multitask rate transition• Single task rate transition• Multitask conditionally executed subsystem• Tasks with equal priority• Enforce sample times specified by Signal Specification blocks• Unspecified inheritability of sample times <p>If the target system does not allow preemption between tasks that have equal priority, set Tasks with equal priority to none.</p>

ID: Title	hisl_0044: Configuration Parameters > Diagnostics > Sample Time	
Note	Enabling diagnostics pertaining to the solver provides information to detect violations of other guidelines.	
	If Diagnostic Parameter...	Is Not Set As Indicated, Then ...
	Source block specifies -1 sample time	Use of inherited sample times for a source block, such as Sine Wave, can go undetected and result in unpredictable execution rates for source and downstream blocks.
	Multitask rate transition	Invalid rate transitions between two blocks operating in multitasking mode can go undetected. You cannot use invalid rate transitions for embedded real-time software applications.
	Single task rate transition	A rate transition between two blocks operating in single-tasking mode can go undetected. You cannot use single-tasking rate transitions for embedded real-time software applications.
	Multitask conditionally executed subsystems	A conditionally executed multirate subsystem, operating in multitasking mode, might go undetected and corrupt data or show unexpected behavior in a target system that allows preemption.
	Tasks with equal priority	Two asynchronous tasks with equal priority might go undetected and show unexpected behavior in target systems that allow preemption.
	Enforce sample times specified by Signal Specification blocks	Inconsistent sample times for a Signal Specification block and the connected destination block might go undetected and result in unpredictable execution rates.

ID: Title		hisl_0044: Configuration Parameters > Diagnostics > Sample Time	
	If Diagnostic Parameter...	Is Not Set As Indicated, Then ...	
	Unspecified inheritability of sample times	An S-function that is not explicitly set to inherit sample time can go undetected and result in unpredictable behavior.	
Rationale	A	Support generation of robust and unambiguous code.	
Model Advisor Checks	<ul style="list-style-type: none"> • By Task > Modeling Standards for DO-178C/DO-331 > High-Integrity Systems > Configuration > Check safety-related diagnostic settings for sample time • By Task > Modeling Standards for IEC 61508 > High-Integrity Systems > Configuration > Check safety-related diagnostic settings for sample time • By Task > Modeling Standards for IEC 62304 > High-Integrity Systems > Configuration > Check safety-related diagnostic settings for sample time • By Task > Modeling Standards for EN 50128 > High-Integrity Systems > Configuration > Check safety-related diagnostic settings for sample time • By Task > Modeling Standards for ISO 26262 > High-Integrity Systems > Configuration > Check safety-related diagnostic settings for sample time <p>For DO-178C/DO-331 check details, see Check safety-related diagnostic settings for sample time.</p> <p>For IEC 61508, IEC 62304, EN 50128, and ISO 26262 check details, see Check safety-related diagnostic settings for sample time.</p>		

ID: Title	hisl_0044: Configuration Parameters > Diagnostics > Sample Time
References	<ul style="list-style-type: none"> • IEC 61508-3, Table A.3 (3) 'Language subset' • IEC 62304, 5.5.3 - Software Unit acceptance criteria • ISO 26262-6, Table 1 (1b) 'Use of language subsets' • EN 50128, Table A.4 (11) 'Language Subset' • DO-331, Section MB.6.3.1.b 'High-level requirements are accurate and consistent' • DO-331, Section MB.6.3.2.b 'Low-level requirements are accurate and consistent' • DO-331, Section MB.6.3.3.b 'Software architecture is consistent'
See Also	"Model Configuration Parameters: Sample Time Diagnostics" in the Simulink documentation
Last Changed	R2017b

hisl_0301: Configuration Parameters > Diagnostics > Compatibility

ID: Title	hisl_0301: Configuration Parameters > Diagnostics > Compatibility
Description	<p>For models used to develop high-integrity systems, in the Configuration Parameters dialog box, on the Diagnostics > Compatibility pane, set the Compatibility parameters as follows:</p> <p>S-function upgrades needed to error</p>
Rationale	Improve robustness of design.

ID: Title	hisl_0301: Configuration Parameters > Diagnostics > Compatibility
<p>Model Advisor Checks</p>	<ul style="list-style-type: none"> • By Task > Modeling Standards for DO-178C/DO-331 > High-Integrity Systems > Configuration > Check safety-related diagnostic settings for compatibility • By Task > Modeling Standards for IEC 61508 > High-Integrity Systems > Configuration > Check safety-related diagnostic settings for compatibility • By Task > Modeling Standards for IEC 62304 > High-Integrity Systems > Configuration > Check safety-related diagnostic settings for compatibility • By Task > Modeling Standards for EN 50128 > High-Integrity Systems > Configuration > Check safety-related diagnostic settings for compatibility • By Task > Modeling Standards for ISO 26262 > High-Integrity Systems > Configuration > Check safety-related diagnostic settings for compatibility <p>For DO-178C/DO-331 check details, see Check safety-related diagnostic settings for compatibility.</p> <p>For IEC 61508, IEC 62304, EN 50128, and ISO 26262 check details, see Check safety-related diagnostic settings for compatibility.</p>
<p>References</p>	<ul style="list-style-type: none"> • DO-331, Section MB.6.3.3.b - Software architecture is consistent • IEC 61508-3, Table A.4 (3) 'Defensive Programming' • IEC 62304, 5.5.3 - Software Unit acceptance criteria • ISO 26262-6, Table 1 (1d) 'Use of defensive implementation techniques' • EN 50128, Table A.3 (1) 'Defensive Programming'
<p>See Also</p>	<p>"Model Configuration Parameters: Compatibility Diagnostics" in the Simulink documentation</p>
<p>Last Changed</p>	<p>R2017b</p>

hisl_0302: Configuration Parameters > Diagnostics > Data Validity > Parameters

ID: Title	hisl_0302: Configuration Parameters > Diagnostics > Data Validity > Parameters
Description	<p>For models used to develop high-integrity systems, in the Configuration Parameters dialog box, on the Diagnostics > Data Validity pane, set the Parameters parameters as follows:</p> <ul style="list-style-type: none"> • Detect downcast to error • Detect precision loss to error • Detect overflow to error • Detect underflow to error
Rationale	Improve robustness of design.
Model Advisor Checks	<ul style="list-style-type: none"> • By Task > Modeling Standards for DO-178C/DO-331 > High-Integrity Systems > Configuration > Check safety-related diagnostic settings for parameters • By Task > Modeling Standards for IEC 61508 > High-Integrity Systems > Configuration > Check safety-related diagnostic settings for parameters • By Task > Modeling Standards for IEC 62304 > High-Integrity Systems > Configuration > Check safety-related diagnostic settings for parameters • By Task > Modeling Standards for EN 50128 > High-Integrity Systems > Configuration > Check safety-related diagnostic settings for parameters • By Task > Modeling Standards for ISO 26262 > High-Integrity Systems > Configuration > Check safety-related diagnostic settings for parameters <p>For DO-178C/DO-331 check details, see Check safety-related diagnostic settings for parameters.</p> <p>For IEC 61508, IEC 62304, EN 50128, and ISO 26262 check details, see Check safety-related diagnostic settings for parameters.</p>

ID: Title	hisl_0302: Configuration Parameters > Diagnostics > Data Validity > Parameters
References	<ul style="list-style-type: none"> • DO-331, Section MB.6.3.1.g - Algorithms are accurate • DO-331, Section MB.6.3.2.g - Algorithms are accurate. • IEC 61508-3, Table A.4 (3) 'Defensive Programming' • IEC 62304, 5.5.3 - Software Unit acceptance criteria • ISO 26262-6, Table 1 (1d) 'Use of defensive implementation techniques' • EN 50128, Table A.3 (1) 'Defensive Programming'
See Also	"Model Configuration Parameters: Data Validity Diagnostics" in the Simulink documentation
Last Changed	R2017b

hisl_0303: Configuration Parameters > Diagnostics > Merge block

ID: Title	hisl_0303: Configuration Parameters > Diagnostics > Merge block
Description	For models used to develop high-integrity systems, in the Configuration Parameters dialog box, set: <ul style="list-style-type: none"> • Detect multiple driving blocks executing at the same time step to error
Rationale	Improve robustness of design.

ID: Title	hisl_0303: Configuration Parameters > Diagnostics > Merge block
Model Advisor Checks	<ul style="list-style-type: none"> • By Task > Modeling Standards for DO-178C/DO-331 > High-Integrity Systems > Configuration > Check safety-related diagnostic settings for Merge blocks • By Task > Modeling Standards for IEC 61508 > High-Integrity Systems > Configuration > Check safety-related diagnostic settings for Merge blocks • By Task > Modeling Standards for IEC 62304 > High-Integrity Systems > Configuration > Check safety-related diagnostic settings for Merge blocks • By Task > Modeling Standards for EN 50128 > High-Integrity Systems > Configuration > Check safety-related diagnostic settings for Merge blocks • By Task > Modeling Standards for ISO 26262 > High-Integrity Systems > Configuration > Check safety-related diagnostic settings for Merge blocks <p>For DO-178C/DO-331 check details, see Check safety-related diagnostic settings for Merge blocks.</p> <p>For IEC 61508, IEC 62304, EN 50128, and ISO 26262 check details, see Check safety-related diagnostic settings for Merge blocks.</p>
References	<ul style="list-style-type: none"> • DO-331 MB.6.3.2 (b) Accuracy and Consistency • IEC 61508-3, Table A.3 (3) - Language subset • IEC 62304, 5.5.3 - Software Unit acceptance criteria • ISO 26262-6, Table 1 (1b) - Use of language subsets • EN 50128, Table A.4 (11) - Language Subset
See Also	“Detect multiple driving blocks executing at the same time step” in the Simulink documentation
Last Changed	R2017b

hisl_0304: Configuration Parameters > Diagnostics > Model initialization

ID: Title	hisl_0304: Configuration Parameters > Diagnostics > Model initialization
Description	<p>For models used to develop high-integrity systems, in the Configuration Parameters dialog box, set:</p> <ul style="list-style-type: none"> • Underspecified initialization detection to Simplified
Rationale	Improve robustness of design.
Model Advisor Checks	<ul style="list-style-type: none"> • By Task > Modeling Standards for DO-178C/DO-331 > High-Integrity Systems > Configuration > Check safety-related diagnostic settings for model initialization • By Task > Modeling Standards for IEC 61508 > High-Integrity Systems > Configuration > Check safety-related diagnostic settings for model initialization • By Task > Modeling Standards for IEC 62304 > High-Integrity Systems > Configuration > Check safety-related diagnostic settings for model initialization • By Task > Modeling Standards for EN 50128 > High-Integrity Systems > Configuration > Check safety-related diagnostic settings for model initialization • By Task > Modeling Standards for ISO 26262 > High-Integrity Systems > Configuration > Check safety-related diagnostic settings for model initialization <p>For DO-178C/DO-331 check details, see Check safety-related diagnostic settings for model initialization.</p> <p>For IEC 61508, IEC 62304, EN 50128, and ISO 26262 check details, see Check safety-related diagnostic settings for model initialization.</p>

ID: Title	hisl_0304: Configuration Parameters > Diagnostics > Model initialization
References	<ul style="list-style-type: none"> • DO-331, Section MB.6.3.3.b - Software architecture is consistent • IEC 61508-3, Table A.3 (3) - Language subset • IEC 62304, 5.5.3 - Software Unit acceptance criteria • ISO 26262-6, Table 1 (1b) - Use of language subsets • EN 50128, Table A.4 (11) - Language Subset • MISRA C:2012, Rule 9.1
See Also	“Underspecified initialization detection” in the Simulink documentation
Last Changed	R2017b

hisl_0305: Configuration Parameters > Diagnostics > Debugging

ID: Title	hisl_0305: Configuration Parameters > Diagnostics > Debugging
Description	For models used to develop high-integrity systems, in the Configuration Parameters dialog, set Model Verification block enabling to <code>Disable all</code> .
Rationale	Improve robustness of design.

ID: Title	hisl_0305: Configuration Parameters > Diagnostics > Debugging
Model Advisor Checks	<ul style="list-style-type: none"> • By Task > Modeling Standards for DO-178C/DO-331 > High-Integrity Systems > Configuration > Check safety-related diagnostic settings for data used for debugging • By Task > Modeling Standards for IEC 61508 > High-Integrity Systems > Configuration > Check safety-related diagnostic settings for data used for debugging • By Task > Modeling Standards for IEC 62304 > High-Integrity Systems > Configuration > Check safety-related diagnostic settings for data used for debugging • By Task > Modeling Standards for EN 50128 > High-Integrity Systems > Configuration > Check safety-related diagnostic settings for data used for debugging • By Task > Modeling Standards for ISO 26262 > High-Integrity Systems > Configuration > Check safety-related diagnostic settings for data used for debugging <p>For DO-178C/DO-331 check details, see Check safety-related diagnostic settings for data used for debugging.</p> <p>For IEC 61508, IEC 62304, EN 50128, and ISO 26262 check details, see Check safety-related diagnostic settings for data used for debugging.</p>
References	<ul style="list-style-type: none"> • DO-331, Section MB.6.3.1.e - High-level requirements conform to standards • DO-331, Section MB.6.3.2.e - Low-level requirements conform to standards • IEC 61508-3, Table A.3 (3) - Language subset • IEC 62304, 5.5.3 - Software Unit acceptance criteria • ISO 26262-6, Table 1 (1b) - Use of language subsets • EN 50128, Table A.4 (11) - Language Subset
See Also	"Model Verification block enabling" in the Simulink documentation
Last Changed	R2017b

hisl_0306: Configuration Parameters > Diagnostics > Connectivity > Signals

ID: Title	hisl_0306: Configuration Parameters > Diagnostics > Connectivity > Signals
Description	<p>For models used to develop high-integrity systems, in the Configuration Parameters dialog box, on the Diagnostics > Connectivity pane, set the Signals parameters as follows:</p> <ul style="list-style-type: none"> • Signal label mismatch to error • Unconnected block input ports to error • Unconnected block output ports to error • Unconnected line to error
Rationale	Improve robustness of design.
Model Advisor Checks	<ul style="list-style-type: none"> • By Task > Modeling Standards for DO-178C/DO-331 > High-Integrity Systems > Configuration > Check safety-related diagnostic settings for signal connectivity • By Task > Modeling Standards for IEC 61508 > High-Integrity Systems > Configuration > Check safety-related diagnostic settings for signal connectivity • By Task > Modeling Standards for IEC 62304 > High-Integrity Systems > Configuration > Check safety-related diagnostic settings for signal connectivity • By Task > Modeling Standards for EN 50128 > High-Integrity Systems > Configuration > Check safety-related diagnostic settings for signal connectivity • By Task > Modeling Standards for ISO 26262 > High-Integrity Systems > Configuration > Check safety-related diagnostic settings for signal connectivity <p>For DO-178C/DO-331 check details, see Check safety-related diagnostic settings for signal connectivity.</p> <p>For IEC 61508, IEC 62304, EN 50128, and ISO 26262 check details, see Check safety-related diagnostic settings for signal connectivity.</p>

ID: Title	hisl_0306: Configuration Parameters > Diagnostics > Connectivity > Signals
References	<ul style="list-style-type: none"> • DO-331, Section MB.6.3.1.e - High-level requirements conform to standards • DO-331, Section MB.6.3.2.e - Low-level requirements conform to standards • IEC 61508-3, Table A.3 (3) - Language subset • IEC 62304, 5.5.3 - Software Unit acceptance criteria • ISO 26262-6, Table 1 (1b) - Use of language subsets • EN 50128, Table A.4 (11) - Language Subset
See Also	“Model Configuration Parameters: Connectivity Diagnostics” in the Simulink documentation
Last Changed	R2017b

hisl_0307: Configuration Parameters > Diagnostics > Connectivity > Buses

ID: Title	hisl_0307: Configuration Parameters > Diagnostics > Connectivity > Buses
Description	<p>For models used to develop high-integrity systems, in the Configuration Parameters dialog box, on the Diagnostics > Connectivity pane, set the Buses parameters as follows:</p> <ul style="list-style-type: none"> • Unspecified bus object at root Output block to error • Element name mismatch to error • Non-bus signals treated as bus signals to error • Repair bus selections to Warn and repair
Rationale	Improve robustness of design.

ID: Title	hisl_0307: Configuration Parameters > Diagnostics > Connectivity > Buses
Model Advisor Checks	<ul style="list-style-type: none"> • By Task > Modeling Standards for DO-178C/DO-331 > High-Integrity Systems > Configuration > Check safety-related diagnostic settings for bus connectivity • By Task > Modeling Standards for IEC 61508 > High-Integrity Systems > Configuration > Check safety-related diagnostic settings for bus connectivity • By Task > Modeling Standards for IEC 62304 > High-Integrity Systems > Configuration > Check safety-related diagnostic settings for bus connectivity • By Task > Modeling Standards for EN 50128 > High-Integrity Systems > Configuration > Check safety-related diagnostic settings for bus connectivity • By Task > Modeling Standards for ISO 26262 > High-Integrity Systems > Configuration > Check safety-related diagnostic settings for bus connectivity <p>For DO-178C/DO-331 check details, see Check safety-related diagnostic settings for bus connectivity.</p> <p>For IEC 61508, IEC 62304, EN 50128, and ISO 26262 check details, see Check safety-related diagnostic settings for bus connectivity.</p>
References	<ul style="list-style-type: none"> • DO-331, Section MB.6.3.3.b - Software architecture is consistent • IEC 61508-3, Table A.3 (3) - Language subset • IEC 62304, 5.5.3 - Software Unit acceptance criteria • ISO 26262-6, Table 1 (1b) - Use of language subsets • EN 50128, Table A.4 (11) - Language Subset
See Also	"Model Configuration Parameters: Connectivity Diagnostics" in the Simulink documentation
Last Changed	R2017b

hisl_0308: Configuration Parameters > Diagnostics > Connectivity > Function calls

ID: Title	hisl_0308: Configuration Parameters > Diagnostics > Connectivity > Function calls
Description	<p>For models used to develop high-integrity systems, in the Configuration Parameters dialog box, on the Diagnostics > Connectivity pane, set the Function calls parameters as follows:</p> <ul style="list-style-type: none"> • Invalid function-call connection to error • Context-dependent inputs to Enable all as errors
Rationale	Improve robustness of design.
Model Advisor Checks	<ul style="list-style-type: none"> • By Task > Modeling Standards for DO-178C/DO-331 > High-Integrity Systems > Configuration > Check safety-related diagnostic settings that apply to function-call connectivity • By Task > Modeling Standards for IEC 61508 > High-Integrity Systems > Configuration > Check safety-related diagnostic settings that apply to function-call connectivity • By Task > Modeling Standards for IEC 62304 > High-Integrity Systems > Configuration > Check safety-related diagnostic settings that apply to function-call connectivity • By Task > Modeling Standards for EN 50128 > High-Integrity Systems > Configuration > Check safety-related diagnostic settings that apply to function-call connectivity • By Task > Modeling Standards for ISO 26262 > High-Integrity Systems > Configuration > Check safety-related diagnostic settings that apply to function-call connectivity <p>For DO-178C/DO-331 check details, see Check safety-related diagnostic settings that apply to function-call connectivity.</p> <p>For IEC 61508, IEC 62304, EN 50128, and ISO 26262 check details, see Check safety-related diagnostic settings that apply to function-call connectivity.</p>

ID: Title	hisl_0308: Configuration Parameters > Diagnostics > Connectivity > Function calls
References	<ul style="list-style-type: none"> • DO-331, Section MB.6.3.3.b - Software architecture is consistent • IEC 61508-3, Table A.3 (3) - Language subset • IEC 62304, 5.5.3 - Software Unit acceptance criteria • ISO 26262-6, Table 1 (1b) - Use of language subsets • EN 50128, Table A.4 (11) - Language Subset
See Also	“Model Configuration Parameters: Connectivity Diagnostics” in the Simulink documentation
Last Changed	R2017b

hisl_0309: Configuration Parameters > Diagnostics > Type Conversion

ID: Title	hisl_0309: Configuration Parameters > Diagnostics > Type Conversion
Description	<p>For models used to develop high-integrity systems, in the Configuration Parameters dialog box, on the Diagnostics > Type Conversion pane, set the Type Conversion parameters as follows:</p> <ul style="list-style-type: none"> • Vector/matrix block input conversion to error • Unnecessary type conversion to warning • 32-bit integer to single precision float conversion to warning
Rationale	Improve robustness of design.

ID: Title	hisl_0309: Configuration Parameters > Diagnostics > Type Conversion
<p>Model Advisor Checks</p>	<ul style="list-style-type: none"> • By Task > Modeling Standards for DO-178C/DO-331 > High-Integrity Systems > Configuration > Check safety-related diagnostic settings for type conversions • By Task > Modeling Standards for IEC 61508 > High-Integrity Systems > Configuration > Check safety-related diagnostic settings for type conversions • By Task > Modeling Standards for IEC 62304 > High-Integrity Systems > Configuration > Check safety-related diagnostic settings for type conversions • By Task > Modeling Standards for EN 50128 > High-Integrity Systems > Configuration > Check safety-related diagnostic settings for type conversions • By Task > Modeling Standards for ISO 26262 > High-Integrity Systems > Configuration > Check safety-related diagnostic settings for type conversions <p>For DO-178C/DO-331 check details, see Check safety-related diagnostic settings for type conversions.</p> <p>For IEC 61508, IEC 62304, EN 50128, and ISO 26262 check details, see Check safety-related diagnostic settings for type conversions.</p>
<p>References</p>	<ul style="list-style-type: none"> • DO-331, Section MB.6.3.1.g - Algorithms are accurate • DO-331, Section MB.6.3.2.g - Algorithms are accurate • IEC 61508-3, Table A.3 (2) Strongly typed programming language • IEC 61508-3, Table A.4 (3) Defensive programming • IEC 62304, 5.5.3 - Software Unit acceptance criteria • ISO 26262-6, Table 1 (1b) Use of language subsets • ISO 26262-6, Table 1 (1c) Enforcement of strong typing • ISO 26262-6, Table 1 (1d) Use of defensive implementation techniques • EN 50128, Table A.4 (8) Strongly Typed Programming Language • EN 50128, Table A.3 (1) Defensive Programming
<p>See Also</p>	<p>“Model Configuration Parameters: Type Conversion Diagnostics” in the Simulink documentation</p>
<p>Last Changed</p>	<p>R2017b</p>

hisl_0310: Configuration Parameters > Diagnostics > Model Referencing

ID: Title	hisl_0310: Configuration Parameters > Diagnostics > Model Referencing
Description	<p>For models used to develop high-integrity systems, in the Configuration Parameters dialog box, on the Diagnostics > Model Referencing pane, set the Model Referencing parameters as follows:</p> <ul style="list-style-type: none"> • Model block version mismatch to none • Port and parameter mismatch to error • Invalid root Inport/Outport block connection to error • Unsupported data logging to error
Rationale	Improve robustness of design.
Model Advisor Checks	<ul style="list-style-type: none"> • By Task > Modeling Standards for DO-178C/DO-331 > High-Integrity Systems > Configuration > Check safety-related diagnostic settings for model referencing • By Task > Modeling Standards for IEC 61508 > High-Integrity Systems > Configuration > Check safety-related diagnostic settings for model referencing • By Task > Modeling Standards for IEC 62304 > High-Integrity Systems > Configuration > Check safety-related diagnostic settings for model referencing • By Task > Modeling Standards for EN 50128 > High-Integrity Systems > Configuration > Check safety-related diagnostic settings for model referencing • By Task > Modeling Standards for ISO 26262 > High-Integrity Systems > Configuration > Check safety-related diagnostic settings for model referencing <p>For DO-178C/DO-331 check details, see Check safety-related diagnostic settings for model referencing.</p> <p>For IEC 61508, IEC 62304, EN 50128, and ISO 26262 check details, see Check safety-related diagnostic settings for model referencing.</p>

ID: Title	hisl_0310: Configuration Parameters > Diagnostics > Model Referencing
References	<ul style="list-style-type: none"> • DO-331, Section MB.6.3.1.d - High-level requirements are verifiable • DO-331, Section MB.6.3.2.d - Low-level requirements are verifiable. • DO-331, Section MB.6.3.3.b - Software architecture is consistent • IEC 61508-3, Table A.3 (3) - Language subset • IEC 62304, 5.5.3 - Software Unit acceptance criteria • ISO 26262-6, Table 1 (1b) - Use of language subsets • EN 50128, Table A.4 (11) - Language Subset
See Also	“Model Configuration Parameters: Model Referencing Diagnostics” in the Simulink documentation
Last Changed	R2018a

hisl_0311: Configuration Parameters > Diagnostics > Stateflow

ID: Title	hisl_0311: Configuration Parameters > Diagnostics > Stateflow
Description	<p>For models used to develop high-integrity systems, in the Configuration Parameters dialog box, on the Diagnostics > Stateflow pane, set these parameters:</p> <ul style="list-style-type: none"> • Unexpected backtracking to error • Invalid input data access in chart initialization to error • No unconditional default transitions to error • Transitions outside natural parent to error • Unreachable execution path to error
Rationale	Improve robustness of design and promote a clear modeling style.

ID: Title	hisl_0311: Configuration Parameters > Diagnostics > Stateflow
Model Advisor Checks	<ul style="list-style-type: none"> • By Task > Modeling Standards for DO-178C/DO-331 > High-Integrity Systems > Configuration > Check safety-related diagnostic settings for Stateflow • By Task > Modeling Standards for IEC 61508 > High-Integrity Systems > Configuration > Check safety-related diagnostic settings for Stateflow • By Task > Modeling Standards for IEC 62304 > High-Integrity Systems > Configuration > Check safety-related diagnostic settings for Stateflow • By Task > Modeling Standards for EN 50128 > High-Integrity Systems > Configuration > Check safety-related diagnostic settings for Stateflow • By Task > Modeling Standards for ISO 26262 > High-Integrity Systems > Configuration > Check safety-related diagnostic settings for Stateflow <p>For DO-178C/DO-331 check details, see Check safety-related diagnostic settings for Stateflow.</p> <p>For IEC 61508, IEC 62304, EN 50128, and ISO 26262 check details, see Check safety-related diagnostic settings for Stateflow.</p>
References	<ul style="list-style-type: none"> • DO-331, Section MB.6.3.1.b 'High-level requirements are accurate and consistent' • DO-331, Section MB.6.3.1.e 'High-level requirements conform to standards' • DO-331, Section MB.6.3.1.g 'Algorithms are accurate' • DO-331, Section MB.6.3.2.b 'Low-level requirements are accurate and consistent' • DO-331, Section MB.6.3.2.d 'Low-level requirements are verifiable' • DO-331, Section MB.6.3.2.e 'Low-level requirements conform to standards' • DO-331, Section MB.6.3.2.g 'Algorithms are accurate' • EN 50128, Table A.4 (11) - Language Subset • IEC 62304, 5.5.3 - Software Unit acceptance criteria • ISO 26262-6, Table 1 (1b) - Use of language subsets • IEC 61508-3, Table A.3 (3) - Language subset
See Also	"Model Configuration Parameters: Stateflow Diagnostics" in the Simulink documentation
Last Changed	R2017b

hisl_0314: Configuration Parameters > Diagnostics > Data Validity > Signals

ID: Title	hisl_0314: Configuration Parameters > Diagnostics > Data Validity > Signals
Description	<p>For models used to develop high-integrity systems, in the Configuration Parameters dialog box, on the Diagnostics > Data Validity pane, set the Signals parameters as follows:</p> <ul style="list-style-type: none">• Signal resolution to Explicit only• Division by singular matrix to error• Underspecified data types to error• Wrap on overflow to error• Saturate on overflow to error• Inf or NaN block output to error• “rt” prefix for identifiers to error• Simulation range checking to error
Rationale	Improve robustness of design.

ID: Title	hisl_0314: Configuration Parameters > Diagnostics > Data Validity > Signals
Model Advisor Checks	<ul style="list-style-type: none"> • By Task > Modeling Standards for DO-178C/DO-331 > High-Integrity Systems > Configuration > Check safety-related diagnostic settings for signal data • By Task > Modeling Standards for IEC 61508 > High-Integrity Systems > Configuration > Check safety-related diagnostic settings for signal data • By Task > Modeling Standards for IEC 62304 > High-Integrity Systems > Configuration > Check safety-related diagnostic settings for signal data • By Task > Modeling Standards for EN 50128 > High-Integrity Systems > Configuration > Check safety-related diagnostic settings for signal data • By Task > Modeling Standards for ISO 26262 > High-Integrity Systems > Configuration > Check safety-related diagnostic settings for signal data <p>For DO-178C/DO-331 check details, see Check safety-related diagnostic settings for signal data.</p> <p>For IEC 61508, IEC 62304, EN 50128, and ISO 26262 check details, see Check safety-related diagnostic settings for signal data.</p>

ID: Title	hisl_0314: Configuration Parameters > Diagnostics > Data Validity > Signals
References	<ul style="list-style-type: none"> • DO-331, Section MB.6.4.2.2 'Robustness Test Cases' DO-331, Section MB.6.4.3 'Requirements-Based Testing Methods' DO-331, Section MB.6.3.1.e 'High-level requirements conform to standards' DO-331, Section MB.6.3.2.e 'Low-level requirements conform to standards' DO-331, Section MB.6.3.1.g 'Algorithms are accurate' DO-331, Section MB.6.3.2.g 'Algorithms are accurate' DO-331, Section MB.6.3.3.b 'Software architecture is consistent' • IEC 61508-3, Table A.3 (3) 'Language subset' IEC 61508-3, Table A.4 (3) 'Defensive programming' • IEC 62304, 5.5.3 - Software Unit acceptance criteria • ISO 26262-6, Table 1 (1b) 'Use of language subsets' ISO 26262-6, Table 1 (1d) 'Use of defensive implementation techniques' • EN 50128, Table A.4 (11) 'Language Subset' EN 50128, Table A.3 (1) 'Defensive Programming' • MISRA C:2012, Dir 4.1
See Also	"Model Configuration Parameters: Data Validity Diagnostics"
Last Changed	R2018a

Model Referencing

hisl_0037: Configuration Parameters > Model Referencing

ID: Title	hisl_0037: Configuration Parameters > Model Referencing	
Description	For models used to develop high-integrity systems, in the Configuration Parameters dialog box, on the Model Referencing pane, set the Options for all referenced models and Options for referencing this model parameters as follows:	
	A	Set Rebuild to either Never or If any changes detected.
	B	Set Never rebuild diagnostic to Error if rebuild required. This diagnostic parameter is available only if Rebuild is set to Never.
	C	Clear Pass fixed-size scalar root inputs by value for code generation .
	D	Clear Minimize algebraic loop occurrences .
Rationale	A	To prevent unnecessary regeneration of the code, resulting in changing only the date of the file and slowing down the build process when using model references.
	B	For safety-related applications, an error should alert model developers that the parent and referenced models are inconsistent.
	C	To prevent unpredictable data because scalar values can change during a time step.
	D	To be compatible with the recommended setting of Single output / update function for embedded systems code.

ID: Title	hisl_0037: Configuration Parameters > Model Referencing
Model Advisor Checks	<ul style="list-style-type: none"> • By Task > Modeling Standards for DO-178C/DO-331 > High-Integrity Systems > Configuration > Check safety-related model referencing settings • By Task > Modeling Standards for IEC 61508 > High-Integrity Systems > Configuration > Check safety-related model referencing settings • By Task > Modeling Standards for IEC 62304 > High-Integrity Systems > Configuration > Check safety-related model referencing settings • By Task > Modeling Standards for EN 50128 > High-Integrity Systems > Configuration > Check safety-related model referencing settings • By Task > Modeling Standards for ISO 26262 > High-Integrity Systems > Configuration > Check safety-related model referencing settings <p>For DO-178C/DO-331 check details, see Check safety-related model referencing settings.</p> <p>For IEC 61508, IEC 62304, EN 50128, and ISO 26262 check details, see Check safety-related model referencing settings.</p>
References	<ul style="list-style-type: none"> • DO-331, Section MB.6.3.1.b 'High-level requirements are accurate and consistent' • DO-331, Section MB.6.3.2.b 'Low-level requirements are accurate and consistent' • DO-331, Section MB.6.3.3.b 'Software architecture is consistent' • IEC 61508-3, Table A.3 (3) 'Language subset' • IEC 61508-3, Table A.4 (3) 'Defensive programming' • IEC 62304, 5.5.3 - Software Unit acceptance criteria • ISO 26262-6, Table 1 (1b) 'Use of language subsets' • ISO 26262-6, Table 1 (1d) 'Use of defensive implementation techniques' • EN 50128, Table A.4 (11) 'Language Subset' • EN 50128, Table A.3 (1) 'Defensive Programming'
Last Changed	R2017b

Code Generation

In this section...

“hisl_0045: Configuration Parameters > Math and Data Types > Implement logic signals as Boolean data (vs. double)” on page 5-39

“hisl_0046: Configuration Parameters > Code Generation > Optimization > Block reduction” on page 5-41

“hisl_0051: Configuration Parameters > Code Generation > Optimization > Loop unrolling threshold” on page 5-43

“hisl_0052: Configuration Parameters > Code Generation > Optimization > Data initialization” on page 5-44

“hisl_0053: Configuration Parameters > Code Generation > Optimization > Remove code from floating-point to integer conversions that wraps out-of-range values” on page 5-46

“hisl_0054: Configuration Parameters > Code Generation > Optimization > Remove code that protects against division arithmetic exceptions” on page 5-48

“hisl_0056: Configuration Parameters > Code Generation > Optimization > Optimize using the specified minimum and maximum values” on page 5-49

“hisl_0038: Configuration Parameters > Code Generation > Comments” on page 5-51

“hisl_0039: Configuration Parameters > Code Generation > Interface” on page 5-53

“hisl_0047: Configuration Parameters > Code Generation > Code Style” on page 5-55

“hisl_0049: Configuration Parameters > Code Generation > Symbols” on page 5-57

hisl_0045: Configuration Parameters > Math and Data Types > Implement logic signals as Boolean data (vs. double)

ID: Title	hisl_0045: Configuration Parameters > Math and Data Types > Implement logic signals as Boolean data (vs. double)
Description	To support unambiguous behavior when using logical operators, relational operators, and the Combinatorial Logic block, select Configuration Parameter Implement logic signals as Boolean data (vs. double)

ID: Title	hisl_0045: Configuration Parameters > Math and Data Types > Implement logic signals as Boolean data (vs. double)
Notes	Selecting Implement logic signals as Boolean data (vs. double) enables Boolean type checking, which produces an error when blocks that prefer Boolean inputs connect to double signals. This checking results in generating code that requires less memory.
Rationale	Avoid ambiguous model behavior and optimize memory for generated code.
Model Advisor Checks	<ul style="list-style-type: none"> • By Task > Modeling Standards for DO-178C/DO-331 > High-Integrity Systems > Configuration > Check safety-related optimization settings • By Task > Modeling Standards for IEC 61508 > High-Integrity Systems > Configuration > Check safety-related optimization settings • By Task > Modeling Standards for IEC 62304 > High-Integrity Systems > Configuration > Check safety-related optimization settings • By Task > Modeling Standards for EN 50128 > High-Integrity Systems > Configuration > Check safety-related optimization settings • By Task > Modeling Standards for ISO 26262 > High-Integrity Systems > Configuration > Check safety-related optimization settings <p>For DO-178C/DO-331 check details, see Check safety-related optimization settings.</p> <p>For IEC 61508, IEC 62304, EN 50128, and ISO 26262 check details, see Check safety-related optimization settings.</p>
References	<ul style="list-style-type: none"> • DO-331, MB.6.3.1.e 'High-level requirements conform to standards' • DO-331, MB.6.3.2.e 'Low-level requirements conform to standards' • IEC 61508-3, Table A.3 (2) 'Strongly typed programming language' • IEC 62304, 5.5.3 - Software Unit acceptance criteria • ISO 26262-6, Table 1 (1c) 'Enforcement of strong typing' • EN 50128, Table A.4 (8) 'Strongly Typed Programming Language' • MISRA C:2012, Rule 10.1

ID: Title	hisl_0045: Configuration Parameters > Math and Data Types > Implement logic signals as Boolean data (vs. double)
See Also	Implement logic signals as Boolean data (vs. double) in the Simulink documentation.
Last Changed	R2018a

hisl_0046: Configuration Parameters > Code Generation > Optimization > Block reduction

ID: Title	hisl_0046: Configuration Parameters > Code Generation > Optimization > Block reduction
Description	To support unambiguous presentation of the generated code and support traceability between a model and generated code, clear Configuration Parameter Block reduction
Notes	Selecting Block reduction might optimize blocks out of the code generated for a model. This results in requirements without associated code and violates traceability objectives.
Rationale	Supports: <ul style="list-style-type: none"> • Unambiguous presentation of generated code • Traceability between a model and generated code

ID: Title	hisl_0046: Configuration Parameters > Code Generation > Optimization > Block reduction
Model Advisor Checks	<ul style="list-style-type: none"> • By Task > Modeling Standards for DO-178C/DO-331 > High-Integrity Systems > Configuration > Check safety-related optimization settings • By Task > Modeling Standards for IEC 61508 > High-Integrity Systems > Configuration > Check safety-related optimization settings • By Task > Modeling Standards for IEC 62304 > High-Integrity Systems > Configuration > Check safety-related optimization settings • By Task > Modeling Standards for EN 50128 > High-Integrity Systems > Configuration > Check safety-related optimization settings • By Task > Modeling Standards for ISO 26262 > High-Integrity Systems > Configuration > Check safety-related optimization settings <p>For DO-178C/DO-331 check details, see Check safety-related optimization settings.</p> <p>For IEC 61508, IEC 62304, EN 50128, and ISO 26262 check details, see Check safety-related optimization settings.</p>
References	<ul style="list-style-type: none"> • DO-331, Section MB.6.3.4.e ‘Source code is traceable to low-level requirements’ • IEC 61508-3, Clauses 7.4.7.2, 7.4.8.3, and 7.7.2.8 which require to demonstrate that no unintended functionality has been introduced
See Also	“Block reduction” in the Simulink documentation
Last Changed	R2018a

hisl_0051: Configuration Parameters > Code Generation > Optimization > Loop unrolling threshold

ID: Title	hisl_0051: Configuration Parameters > Code Generation > Optimization > Loop unrolling threshold
Description	To support unambiguous code, set the minimum signal or parameter width for generating a for loop by setting Configuration Parameter Loop unrolling threshold to 2 or greater.
Notes	Loop unrolling threshold specifies the array size at which the code generator begins to use a for loop, instead of separate assignment statements, to assign values to the elements of a signal or parameter array. The default value is 5.
Rationale	Support unambiguous generated code.
Model Advisor Checks	<ul style="list-style-type: none"> • By Task > Modeling Standards for DO-178C/DO-331 > High-Integrity Systems > Configuration > Check safety-related optimization settings for Loop unrolling threshold • By Task > Modeling Standards for IEC 61508 > High-Integrity Systems > Configuration > Check safety-related optimization settings for Loop unrolling threshold • By Task > Modeling Standards for IEC 62304 > High-Integrity Systems > Configuration > Check safety-related optimization settings for Loop unrolling threshold • By Task > Modeling Standards for EN 50128 > High-Integrity Systems > Configuration > Check safety-related optimization settings for Loop unrolling threshold • By Task > Modeling Standards for ISO 26262 > High-Integrity Systems > Configuration > Check safety-related optimization settings for Loop unrolling threshold <p>For DO-178C/DO-331 check details, see Check safety-related optimization settings for Loop unrolling threshold.</p> <p>For IEC 61508, IEC 62304, EN 50128, and ISO 26262 check details, see Check safety-related optimization settings for Loop unrolling threshold.</p>

ID: Title	hisl_0051: Configuration Parameters > Code Generation > Optimization > Loop unrolling threshold
References	<ul style="list-style-type: none"> • DO-331 Section MB.6.3.4.e—Source code is traceable to low-level requirements. • IEC 61508-3, Table A.3 (3) 'Language Subset' • IEC 62304, 5.5.3 - Software Unit acceptance criteria • ISO 26262-6, Table 1 (1b) 'Use of language subsets' • EN 50128, Table A.4 (11) 'Language Subset' • MISRA C:2012, Rule 6.1
See Also	“Loop unrolling threshold” (Simulink Coder) in the Simulink documentation
Last Changed	R2018a

hisl_0052: Configuration Parameters > Code Generation > Optimization > Data initialization

ID: Title	hisl_0052: Configuration Parameters > Code Generation > Optimization > Data initialization	
Description	To support complete definition of data and initialize internal and external data to zero, in the Configuration Parameters dialog box:	
	A	Clear Remove root level I/O zero initialization.
	B	Clear Remove internal data zero initialization.
Note	Explicitly initialize all variables. If the run-time environment of the target system provides mechanisms to initialize all I/O and state variables, consider using the initialization of the target as an alternative to the suggested settings.	
Rationale	A, B	Support fully defined data in generated code.

ID: Title	hisl_0052: Configuration Parameters > Code Generation > Optimization > Data initialization
Model Advisor Checks	<ul style="list-style-type: none"> • By Task > Modeling Standards for DO-178C/DO-331 > High-Integrity Systems > Configuration > Check safety-related optimization settings • By Task > Modeling Standards for IEC 61508 > High-Integrity Systems > Configuration > Check safety-related optimization settings • By Task > Modeling Standards for IEC 62304 > High-Integrity Systems > Configuration > Check safety-related optimization settings • By Task > Modeling Standards for EN 50128 > High-Integrity Systems > Configuration > Check safety-related optimization settings • By Task > Modeling Standards for ISO 26262 > High-Integrity Systems > Configuration > Check safety-related optimization settings <p>For DO-178C/DO-331 check details, see Check safety-related optimization settings.</p> <p>For IEC 61508, IEC 62304, EN 50128, and ISO 26262 check details, see Check safety-related optimization settings.</p>
References	<ul style="list-style-type: none"> • DO-331, Section MB.6.3.3.b 'Software architecture is consistent' • IEC 61508-3, Table A.4 (3) 'Defensive Programming' • IEC 62304, 5.5.3 - Software Unit acceptance criteria • ISO 26262-6, Table 1 (1d) 'Use of defensive implementation techniques' • EN 50128, Table A.3 (1) 'Defensive Programming'
See Also	<p>Information about the following parameters in the Simulink documentation:</p> <ul style="list-style-type: none"> • "Remove root level I/O zero initialization" (Simulink Coder) • "Remove internal data zero initialization" (Simulink Coder)
Last Changed	R2018a

hisl_0053: Configuration Parameters > Code Generation > Optimization > Remove code from floating-point to integer conversions that wraps out-of-range values

ID: Title	hisl_0053: Configuration Parameters > Code Generation > Optimization > Remove code from floating-point to integer conversions that wraps out-of-range values
Description	To support verifiable code, in the Configuration Parameters dialog box, select Remove code from floating-point to integer conversions that wraps out-of-range values
Notes	Avoid overflows as opposed to handling them with wrapper code. For blocks that have parameter Saturate on integer overflow cleared, clearing configuration parameter Remove code from floating-point to integer conversions that wraps out-of-range values might add code that wraps out of range values, resulting in unreachable code that cannot be tested.
Rationale	Support generation of code that can be verified.

ID: Title	hisl_0053: Configuration Parameters > Code Generation > Optimization > Remove code from floating-point to integer conversions that wraps out-of-range values
Model Advisor Checks	<ul style="list-style-type: none"> • By Task > Modeling Standards for DO-178C/DO-331 > High-Integrity Systems > Configuration > Check safety-related optimization settings • By Task > Modeling Standards for IEC 61508 > High-Integrity Systems > Configuration > Check safety-related optimization settings • By Task > Modeling Standards for IEC 62304 > High-Integrity Systems > Configuration > Check safety-related optimization settings • By Task > Modeling Standards for EN 50128 > High-Integrity Systems > Configuration > Check safety-related optimization settings • By Task > Modeling Standards for ISO 26262 > High-Integrity Systems > Configuration > Check safety-related optimization settings <p>For DO-178C/DO-331 check details, see Check safety-related optimization settings.</p> <p>For IEC 61508, IEC 62304, EN 50128, and ISO 26262 check details, see Check safety-related optimization settings.</p>
References	<ul style="list-style-type: none"> • DO-331, Section MB.6.3.1.g 'Algorithms are accurate' • DO-331, Section MB.6.3.2.g 'Algorithms are accurate' • IEC 61508-3, Table A.4 (3) 'Defensive Programming' • IEC 62304, 5.5.3 - Software Unit acceptance criteria • ISO 26262-6, Table 1 (1d) 'Use of defensive implementation techniques' • EN 50128, Table A.3 (1) 'Defensive Programming' • MISRA C:2012, Rule 2.1
See Also	"Remove code from floating-point to integer conversions that wraps out-of-range values" (Simulink Coder) in the Simulink documentation
Last Changed	R2018a

hisl_0054: Configuration Parameters > Code Generation > Optimization > Remove code that protects against division arithmetic exceptions

ID: Title	hisl_0054: Configuration Parameters > Code Generation > Optimization > Remove code that protects against division arithmetic exceptions
Description	To support the robustness of the operations, in the Configuration Parameters dialog box, clear Remove code that protects against division arithmetic exceptions .
Note	Avoid division-by-zero exceptions. If you clear Remove code that protects against division arithmetic exceptions , the code generator produces code that guards against division by zero for fixed-point data.
Rationale	Protect against divide-by-zero exceptions for fixed-point code.
Model Advisor Checks	<ul style="list-style-type: none"> • By Task > Modeling Standards for DO-178C/DO-331 > High-Integrity Systems > Configuration > Check safety-related optimization settings • By Task > Modeling Standards for IEC 61508 > High-Integrity Systems > Configuration > Check safety-related optimization settings • By Task > Modeling Standards for IEC 62304 > High-Integrity Systems > Configuration > Check safety-related optimization settings • By Task > Modeling Standards for EN 50128 > High-Integrity Systems > Configuration > Check safety-related optimization settings • By Task > Modeling Standards for ISO 26262 > High-Integrity Systems > Configuration > Check safety-related optimization settings <p>For DO-178C/DO-331 check details, see Check safety-related optimization settings.</p> <p>For IEC 61508, IEC 62304, EN 50128, and ISO 26262 check details, see Check safety-related optimization settings.</p>

ID: Title	hisl_0054: Configuration Parameters > Code Generation > Optimization > Remove code that protects against division arithmetic exceptions
References	<ul style="list-style-type: none"> • DO-331, Section MB.6.3.1.g 'Algorithms are accurate' • DO-331, Section MB.6.3.2.g 'Algorithms are accurate' • IEC 61508-3, Table A.3 (3) 'Language Subset' • IEC 61508-3 Table A.4 (3) 'Defensive Programming' • IEC 62304, 5.5.3 - Software Unit acceptance criteria • ISO 26262-6, Table 1(b) 'Use of language subsets' • ISO 26262-6, Table 1(d) 'Use of defensive implementation techniques' • EN 50128, Table A.4 (11) 'Language Subset' • EN 50128, Table A.3 (1) 'Defensive Programming' • MISRA C:2012, Dir 4.1
See Also	"Remove code that protects against division arithmetic exceptions" (Simulink Coder) in the Simulink documentation
Last Changed	R2018a

hisl_0056: Configuration Parameters > Code Generation > Optimization > Optimize using the specified minimum and maximum values

ID: Title	hisl_0056: Configuration Parameters > Code Generation > Optimization > Optimize using the specified minimum and maximum values
Description	To support verifiable code, clear Configuration Parameter Optimize using the specified minimum and maximum values .
Notes	Selecting Optimize using the specified minimum and maximum values can result in requirements without associated code and violates traceability objectives.
Rationale	Support traceability between a model and generated code.

ID: Title	hisl_0056: Configuration Parameters > Code Generation > Optimization > Optimize using the specified minimum and maximum values
Model Advisor Checks	<ul style="list-style-type: none"> • By Task > Modeling Standards for DO-178C/DO-331 > High-Integrity Systems > Configuration > Check safety-related optimization settings • By Task > Modeling Standards for IEC 61508 > High-Integrity Systems > Configuration > Check safety-related optimization settings • By Task > Modeling Standards for IEC 62304 > High-Integrity Systems > Configuration > Check safety-related optimization settings • By Task > Modeling Standards for EN 50128 > High-Integrity Systems > Configuration > Check safety-related optimization settings • By Task > Modeling Standards for ISO 26262 > High-Integrity Systems > Configuration > Check safety-related optimization settings <p>For DO-178C/DO-331 check details, see Check safety-related optimization settings.</p> <p>For IEC 61508, IEC 62304, EN 50128, and ISO 26262 check details, see Check safety-related optimization settings.</p>
References	<ul style="list-style-type: none"> • DO-331 Section MB.MB.6.3.4.e 'Source code is traceable to low-level requirements' • IEC 61508-3, Clauses 7.4.7.2, 7.4.8.3, and 7.7.2.8 which require to demonstrate that no unintended functionality has been introduced
See also	"Optimize using the specified minimum and maximum values" (Simulink Coder)
Last Changed	R2018a

hisl_0038: Configuration Parameters > Code Generation > Comments

ID: Title	hisl_0038: Configuration Parameters > Code Generation > Comments	
Description	For models used to develop high-integrity systems, in the Configuration Parameters dialog box, on the Code Generation > Comments pane, set the Overall control , Auto generated comments , and Custom comments parameters as follows:	
	A	Select Include comments .
	B	Select Simulink block comments .
	C	Select Show eliminated blocks .
	D	Select Verbose comments for 'Model default' storage class .
	E	Select Requirements in block comments .
Rationale	A	Including comments provides good traceability between the code and the model.
	B	Including comments that describe the code for blocks provides good traceability between the code and the model.
	C	Including comments that describe the code for blocks eliminated from a model provides good traceability between the code and the model.
	D	Including the names of parameter variables and source blocks as comments in the model parameter structure declaration in <i>model_parm.h</i> provides good traceability between the code and the model.
	E	Including requirement descriptions assigned to Simulink blocks as comments provides good traceability between the code and the model.

ID: Title	hisl_0038: Configuration Parameters > Code Generation > Comments
Model Advisor Checks	<ul style="list-style-type: none"> • By Task > Modeling Standards for DO-178C/DO-331 > High-Integrity Systems > Configuration > Check safety-related code generation settings • By Task > Modeling Standards for IEC 61508 > High-Integrity Systems > Configuration > Check safety-related code generation settings • By Task > Modeling Standards for IEC 62304 > High-Integrity Systems > Configuration > Check safety-related code generation settings • By Task > Modeling Standards for EN 50128 > High-Integrity Systems > Configuration > Check safety-related code generation settings • By Task > Modeling Standards for ISO 26262 > High-Integrity Systems > Configuration > Check safety-related code generation settings <p>For DO-178C/DO-331 check details, see Check safety-related code generation settings.</p> <p>For IEC 61508, IEC 62304, EN 50128, and ISO 26262 check details, see Check safety-related code generation settings.</p>
References	<ul style="list-style-type: none"> • DO-331, Section MB.6.3.4.e 'Source code is traceable to low-level requirements' • IEC 61508-3, Table A.3 (3) 'Language subset' • IEC 62304, 5.5.3 - Software Unit acceptance criteria • ISO 26262-6, Table 1 (1b) 'Use of language subsets' • EN 50128, Table A.4 (11) 'Language Subset'
Last Changed	R2017b

hisl_0039: Configuration Parameters > Code Generation > Interface

ID: Title	hisl_0039: Configuration Parameters > Code Generation > Interface	
Description	For models used to develop high-integrity systems, in the Configuration Parameters dialog box, on the Code Generation > Interface pane, set the Software environment , Code interface , and Data exchange interface parameters as follows:	
	A	Clear Support: non-finite numbers .
	B	Clear Support: absolute time .
	C	Clear Support: continuous time .
	D	Clear Support: non-inlined S-functions .
	E	Clear Classic call interface .
	F	Select Single output / update function .
	G	Clear Terminate function required .
	H	Select Suppress error status in real-time model data .
	I	Clear MAT-file logging .
Rationale	A	Support for non-finite numbers is not recommended for real-time safety-related systems.
	B	Support for absolute time is not recommended for real-time safety-related systems.
	C	Support for continuous time is not recommended for real-time safety-related systems.
	D	Support for non-inlined S-functions requires support of non-finite numbers, which is not recommended for real-time safety-related systems.
	E	To eliminate model function calls compatible with the main program module of the pre-2012a GRT target that is not recommended for real-time safety-related systems; use an ERT based target instead.
	F	To simplify the interface to the real-time operating system (RTOS) and simplify verification of the generated code by creating a single call to both the output and update functions.

ID: Title	hisl_0039: Configuration Parameters > Code Generation > Interface	
	G	To eliminate <i>model_terminate</i> function, which is not recommended for real-time safety-related systems.
	H	To eliminate extra code for logging and monitoring error status that might not be reachable for testing.
	I	To eliminate extra code for logging test points to a MAT file that is not supported by embedded targets.
Model Advisor Checks	<ul style="list-style-type: none"> • By Task > Modeling Standards for DO-178C/DO-331 > High-Integrity Systems > Configuration > Check safety-related code generation settings • By Task > Modeling Standards for IEC 61508 > High-Integrity Systems > Configuration > Check safety-related code generation settings • By Task > Modeling Standards for IEC 62304 > High-Integrity Systems > Configuration > Check safety-related code generation settings • By Task > Modeling Standards for EN 50128 > High-Integrity Systems > Configuration > Check safety-related code generation settings • By Task > Modeling Standards for ISO 26262 > High-Integrity Systems > Configuration > Check safety-related code generation settings <p>For DO-178C/DO-331 check details, see Check safety-related code generation settings.</p> <p>For IEC 61508, IEC 62304, EN 50128, and ISO 26262 check details, see Check safety-related code generation settings.</p>	

ID: Title	hisl_0039: Configuration Parameters > Code Generation > Interface
References	<ul style="list-style-type: none"> • DO-331, Section MB.6.3.1.c 'High-level requirements are compatible with target computer' • DO-331, Section MB.6.3.2.c 'Low-level requirements are compatible with target computer' • IEC 61508-3, Table A.3 (3) 'Language subset' • IEC 62304, 5.5.3 - Software Unit acceptance criteria • ISO 26262-6, Table 1 (1b) 'Use of language subsets' • EN 50128, Table A.4 (11) 'Language Subset'
Last Changed	R2017b

hisl_0047: Configuration Parameters > Code Generation > Code Style

ID: Title	hisl_0047: Configuration Parameters > Code Generation > Code	
Description	For models used to develop high-integrity systems, in the Configuration Parameters dialog box, on the Code Generation > Code Style pane, set the Code Style parameters as follows:	
	A	Set Parenthesis level to Maximum (Specify precedence with parentheses).
	B	Select Preserve operand order in expression .
Rationale	C	Select Preserve condition expression in if statement .
	A	To prevent unexpected results.
	B,C	To improve traceability of the generated code.

ID: Title	hisl_0047: Configuration Parameters > Code Generation > Code
Model Advisor Checks	<ul style="list-style-type: none"> • By Task > Modeling Standards for DO-178C/DO-331 > High-Integrity Systems > Configuration > Check safety-related code generation settings • By Task > Modeling Standards for IEC 61508 > High-Integrity Systems > Configuration > Check safety-related code generation settings • By Task > Modeling Standards for IEC 62304 > High-Integrity Systems > Configuration > Check safety-related code generation settings • By Task > Modeling Standards for EN 50128 > High-Integrity Systems > Configuration > Check safety-related code generation settings • By Task > Modeling Standards for ISO 26262 > High-Integrity Systems > Configuration > Check safety-related code generation settings <p>For DO-178C/DO-331 check details, see Check safety-related code generation settings.</p> <p>For IEC 61508, IEC 62304, EN 50128, and ISO 26262 check details, see Check safety-related code generation settings.</p>
References	<ul style="list-style-type: none"> • DO-331, Section MB.6.3.1.c 'High-level requirements are compatible with target computer' • DO-331, Section MB.6.3.2.c 'Low-level requirements are compatible with target computer' • DO-331, Section MB.6.3.4.e 'Source code is traceable to low-level requirements' • IEC 61508-3, Table A.3 (3) 'Language subset' • IEC 62304, 5.5.3 - Software Unit acceptance criteria • ISO 26262-6, Table 1 (1b) 'Use of language subsets' • EN 50128, Table A.4 (11) 'Language Subset' • MISRA C:2012, Rule 12.1
Last Changed	R2017b

hisl_0049: Configuration Parameters > Code Generation > Symbols

ID: Title	hisl_0049: Configuration Parameters > Code Generation > Symbols	
Description	For models used to develop high-integrity systems, in the Configuration Parameters dialog box, on the Code Generation > Symbols pane, set the Auto-generated identifier naming rules parameters as follows:	
	A	Set Minimum mangle length to 4 or greater.
Rationale	A	To minimize the likelihood that parameter and signal names will change during code generation when the model changes. Thus the option can decrease the effort to perform code review.
Model Advisor Checks	<ul style="list-style-type: none"> • By Task > Modeling Standards for DO-178C/DO-331 > High-Integrity Systems > Configuration > Check safety-related code generation settings • By Task > Modeling Standards for IEC 61508 > High-Integrity Systems > Configuration > Check safety-related code generation settings • By Task > Modeling Standards for IEC 62304 > High-Integrity Systems > Configuration > Check safety-related code generation settings • By Task > Modeling Standards for EN 50128 > High-Integrity Systems > Configuration > Check safety-related code generation settings • By Task > Modeling Standards for ISO 26262 > High-Integrity Systems > Configuration > Check safety-related code generation settings <p>For DO-178C/DO-331 check details, see Check safety-related code generation settings.</p> <p>For IEC 61508, IEC 62304, EN 50128, and ISO 26262 check details, see Check safety-related code generation settings.</p>	

ID: Title	hisl_0049: Configuration Parameters > Code Generation > Symbols
References	<ul style="list-style-type: none">• DO-331, Section MB.6.3.4.e 'Source code is traceable to low-level requirements'• IEC 61508-3, Table A.3 (3) 'Language subset'• IEC 62304, 5.5.3 - Software Unit acceptance criteria• ISO 26262-6, Table 1 (1b) 'Use of language subsets'• EN 50128, Table A.4 (11) 'Language Subset'
Last Changed	R2017b

Naming Considerations

Naming Considerations

In this section...

“hisl_0031: Model file names” on page 6-2

“hisl_0032: Model object names” on page 6-3

hisl_0031: Model file names

ID: Title	hisl_0031: Model file names
Description	<p>For model file names:</p> <ul style="list-style-type: none"> • Use these characters: a-z, A-Z, 0-9, and the underscore (_). • Use strings that are more than 2 and less than 64 characters. (<i>Not including the dot and file extension</i>). <p>Do not:</p> <ul style="list-style-type: none"> • Start the name with a number. • Use underscores at the beginning or end of a string. • Use more than one consecutive underscore. • Use underscores in file extensions. • Use reserved identifiers.
Rationale	<ul style="list-style-type: none"> • Readability • Compiler limitations • Model-to-generated code traceability
See Also	<ul style="list-style-type: none"> • MAAB guideline, Version 3.0: ar_0001: Filenames • MAAB guideline, Version 3.0: ar_0002: Directory names • “Reserved Keywords” (Embedded Coder)
Last Changed	R2018a

ID: Title	hisl_0031: Model file names
Examples	<p data-bbox="338 298 535 326">Recommended</p> <ul data-bbox="338 354 569 381" style="list-style-type: none"> <li data-bbox="338 354 569 381">• My_model.slx <p data-bbox="338 409 592 437">Not Recommended</p> <ul data-bbox="338 465 698 579" style="list-style-type: none"> <li data-bbox="338 465 602 493">• _My_model.slx <li data-bbox="338 503 698 531">• 2018_01_11_model.slx <li data-bbox="338 541 491 569">• New.slx

hisl_0032: Model object names

ID: Title	hisl_0032: Model object names
Description	<p data-bbox="338 748 802 775">For the following model object names:</p> <ul data-bbox="338 803 1248 994" style="list-style-type: none"> <li data-bbox="338 803 465 831">• Signals <li data-bbox="338 841 516 869">• Parameters <li data-bbox="338 880 457 907">• Blocks <li data-bbox="338 918 1248 994">• Named Stateflow objects (States, Boxes, Simulink Functions, Graphical Functions, Truth Tables) <p data-bbox="338 1022 394 1050">Use:</p> <ul data-bbox="338 1078 1092 1150" style="list-style-type: none"> <li data-bbox="338 1078 1092 1105">• These characters: a-z, A-Z, 0-9, and the underscore (_). <li data-bbox="338 1116 891 1144">• Strings that are fewer than 32 characters. <p data-bbox="338 1178 427 1206">Do not:</p> <ul data-bbox="338 1234 1013 1390" style="list-style-type: none"> <li data-bbox="338 1234 750 1262">• Start the name with a number. <li data-bbox="338 1272 1013 1300">• Use underscores at the beginning or end of a string. <li data-bbox="338 1310 911 1338">• Use more than one consecutive underscore. <li data-bbox="338 1348 676 1376">• Use reserved identifiers.

ID: Title	hisl_0032: Model object names
Notes	<p>Reserved names:</p> <ul style="list-style-type: none">• MATLAB keywords• Reserved keywords for C, C++, and code generation. For complete list, see “Reserved Keywords” (Simulink Coder).• <code>int8</code>, <code>uint8</code>• <code>int16</code>, <code>uint16</code>• <code>int32</code>, <code>uint32</code>• <code>inf</code>, <code>Inf</code>• <code>NaN</code>, <code>nan</code>• <code>eps</code>• <code>intmin</code>, <code>intmax</code>• <code>realmin</code>, <code>realmax</code>• <code>pi</code>• <code>infinity</code>• <code>Nil</code>
Rationale	<ul style="list-style-type: none">• Readability• Compiler limitations• Model-to-generated code traceability

ID: Title	hisl_0032: Model object names
Model Advisor Checks	<ul style="list-style-type: none"> • By Task > Modeling Standards for DO-178C/DO-331 > High-Integrity Systems > Naming > Check model object names • By Task > Modeling Standards for IEC 61508 > High-Integrity Systems > Naming > Check model object names • By Task > Modeling Standards for IEC 62304 > High-Integrity Systems > Naming > Check model object names • By Task > Modeling Standards for EN 50128 > High-Integrity Systems > Naming > Check model object names • By Task > Modeling Standards for ISO 26262 > High-Integrity Systems > Naming > Check model object names <p>For DO-178C/DO-331 check details, see Check model object names.</p> <p>For IEC 61508, IEC 62304, EN 50128, and ISO 26262 check details, see Check model object names.</p>
See Also	<ul style="list-style-type: none"> • MAAB guideline, Version 3.0: jc_0201: Usable characters for Subsystem names • MAAB guideline, Version 3.0: jc_0211: Usable characters for Inport blocks and Outport blocks • MAAB guideline, Version 3.0: jc_0221: Usable characters for signal line names • MAAB guideline, Version 3.0: jc_0231: Usable characters for block names • MAAB guideline, Version 3.0: na_0019: Restricted Variable Names • MAAB guideline, Version 3.0: na_0030: Usable characters for Simulink Bus names
Last Changed	R2018a
Example	<p>Recommended</p> <ul style="list-style-type: none"> • Block name: My_Controller • Signal name: a_b <p>Not Recommended</p> <ul style="list-style-type: none"> • Block name: My Controller • Signal name: 12a__b

MISRA C:2012 Compliance Considerations

- “Modeling Style” on page 7-2
- “Block Usage” on page 7-13
- “Configuration Settings” on page 7-21
- “Stateflow Chart Considerations” on page 7-26

Modeling Style

In this section...

“hisl_0061: Unique identifiers for clarity” on page 7-2

“hisl_0062: Global variables in graphical functions” on page 7-8

“hisl_0063: Length of user-defined object names to improve MISRA C:2012 compliance” on page 7-10

“hisl_0201: Define reserved keywords to improve MISRA C:2012 compliance” on page 7-12

hisl_0061: Unique identifiers for clarity

ID: Title	hisl_0061: Unique identifiers for clarity	
Description	When developing a model:	
	A	Use unique identifiers for Simulink signals.
	B	Define unique identifiers across multiple scopes within a chart.
Notes	The code generator resolves conflicts between identifiers so that symbols in the generated code are unique. The process is called name mangling.	
Rationale	A, B	Improve readability of a graphical model and mapping between identifiers in the model and generated code.

ID: Title	hisl_0061: Unique identifiers for clarity
Model Advisor Check	<ul style="list-style-type: none"> • By Task > Modeling Standards for DO-178C/DO-331 > High-Integrity Systems > Stateflow > Check Stateflow charts for uniquely defined data objects • By Task > Modeling Standards for IEC 61508 > High-Integrity Systems > Stateflow > Check Stateflow charts for uniquely defined data objects • By Task > Modeling Standards for IEC 62304 > High-Integrity Systems > Stateflow > Check Stateflow charts for uniquely defined data objects • By Task > Modeling Standards for EN 50128 > High-Integrity Systems > Stateflow > Check Stateflow charts for uniquely defined data objects • By Task > Modeling Standards for ISO 26262 > High-Integrity Systems > Stateflow > Check Stateflow charts for uniquely defined data objects <p>For DO-178C/DO-331 check details, see Check Stateflow charts for uniquely defined data objects.</p> <p>For IEC 61508, IEC 62304, EN 50128, and ISO 26262 check details, see Check Stateflow charts for uniquely defined data objects.</p> <hr/> <ul style="list-style-type: none"> • By Task > Modeling Standards for DO-178C/DO-331 > High-Integrity Systems > Stateflow > Check usage of Stateflow constructs • By Task > Modeling Standards for IEC 61508 > High-Integrity Systems > Stateflow > Check usage of Stateflow constructs • By Task > Modeling Standards for IEC 62304 > High-Integrity Systems > Stateflow > Check usage of Stateflow constructs • By Task > Modeling Standards for EN 50128 > High-Integrity Systems > Stateflow > Check usage of Stateflow constructs • By Task > Modeling Standards for ISO 26262 > High-Integrity Systems > Stateflow > Check usage of Stateflow constructs <p>For DO-178C/DO-331 check details, see Check usage of Stateflow constructs.</p> <p>For IEC 61508, IEC 62304, EN 50128, and ISO 26262 check details, see Check usage of Stateflow constructs.</p>

ID: Title	his1_0061: Unique identifiers for clarity
References	<ul style="list-style-type: none"> • DO-331, Section MB.6.3.2.b 'Low-level requirements are accurate and consistent' • IEC 61508-3, Table A.3 (2) 'Strongly typed programming language' • IEC 61508-3, Table A.3 (3) - Language subset • IEC 61508-3, Table A.4 (5) - Design and coding standards • IEC 62304, 5.5.3 - Software Unit acceptance criteria • ISO 26262-6, Table 1 (1b) - Use of language subsets • ISO 26262-6, Table 1 (1c) 'Enforcement of strong typing' • ISO 26262-6, Table 1 (1d) - Use of defensive implementation techniques • ISO 26262-6, Table 1 (1e) - Use of established design principles • ISO 26262-6, Table 1 (1f) - Use of unambiguous graphical representation • ISO 26262-6, Table 1 (1g) - Use of style guides • ISO 26262-6, Table 1 (1h) - Use of naming conventions • EN 50128, Table A.3 (1) - Defensive Programming • EN 50128, Table A.4 (8) 'Strongly Typed Programming Language' • EN 50128, Table A.4 (11) - Language Subset • EN 50128, Table A.12 (1) 'Coding Standard' • EN 50128, Table A.12 (2) 'Coding Style Guide'
See Also	"Code Appearance" (Simulink Coder)
Last Changed	R2017b

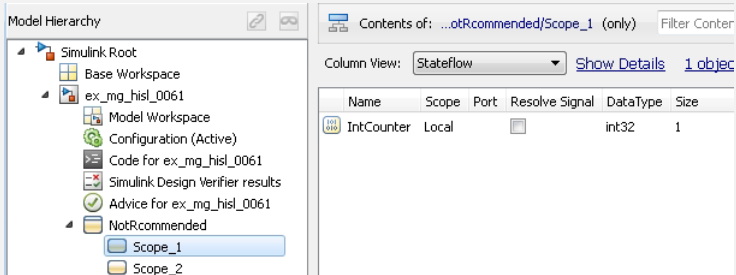
ID: Title	hisl_0061: Unique identifiers for clarity												
Examples	<p data-bbox="372 296 630 329">Not Recommended</p> <p data-bbox="372 355 1224 416">In the following example, two states Scope_1 and Scope_2 use local identifier IntCounter.</p> <div data-bbox="397 494 1243 963" style="border: 1px dashed gray; padding: 10px; margin: 10px 0;"> <p data-bbox="408 503 497 529">Scope_1 1</p> <p data-bbox="408 529 749 555">% IntCounter is defined at this scope</p> <p data-bbox="408 555 467 581">entry:</p> <p data-bbox="408 581 615 607">IntCounter = int32(0);</p> <p data-bbox="408 607 467 633">during:</p> <p data-bbox="408 633 972 659">Chart_Level_Output_S1 = Chart_Level_Input + IntCounter;</p> <p data-bbox="408 659 742 685">IntCounter = IntCounter + int32(1);</p> </div> <div data-bbox="397 737 1243 963" style="border: 1px dashed gray; padding: 10px; margin: 10px 0;"> <p data-bbox="408 746 497 772">Scope_2 2</p> <p data-bbox="408 772 749 798">% IntCounter is defined at this scope</p> <p data-bbox="408 798 467 824">entry:</p> <p data-bbox="408 824 615 850">IntCounter = int32(0);</p> <p data-bbox="408 850 467 876">during:</p> <p data-bbox="408 876 972 902">Chart_Level_Output_S2 = Chart_Level_Input + IntCounter;</p> <p data-bbox="408 902 742 928">IntCounter = IntCounter + int32(1);</p> </div> <p data-bbox="372 1024 1313 1058">The identifier IntCounter is defined for two states, Scope_1 and Scope_2.</p>  <table border="1" data-bbox="690 1171 1105 1223"> <thead> <tr> <th>Name</th> <th>Scope</th> <th>Port</th> <th>Resolve Signal</th> <th>DataType</th> <th>Size</th> </tr> </thead> <tbody> <tr> <td>IntCounter</td> <td>Local</td> <td></td> <td></td> <td>int32</td> <td>1</td> </tr> </tbody> </table>	Name	Scope	Port	Resolve Signal	DataType	Size	IntCounter	Local			int32	1
Name	Scope	Port	Resolve Signal	DataType	Size								
IntCounter	Local			int32	1								

ID: Title	hisl_0061: Unique identifiers for clarity													
	<p>Model Hierarchy</p> <ul style="list-style-type: none"> Simulink Root <ul style="list-style-type: none"> Base Workspace ex_mg_hisl_0061 <ul style="list-style-type: none"> Model Workspace Configuration (Active) Code for ex_mg_hisl_0061 Simulink Design Verifier results Advice for ex_mg_hisl_0061 NotRecommended <ul style="list-style-type: none"> Scope_1 Scope_2 	<p>Contents of: ...otRecommended/Scope_2 (only) Filter Contents</p> <p>Column View: Stateflow Show Details 1 object(s)</p> <table border="1"> <thead> <tr> <th>Name</th> <th>Scope</th> <th>Port</th> <th>Resolve Signal</th> <th>DataType</th> <th>Size</th> </tr> </thead> <tbody> <tr> <td>IntCounter</td> <td>Local</td> <td></td> <td><input type="checkbox"/></td> <td>int32</td> <td>1</td> </tr> </tbody> </table>	Name	Scope	Port	Resolve Signal	DataType	Size	IntCounter	Local		<input type="checkbox"/>	int32	1
Name	Scope	Port	Resolve Signal	DataType	Size									
IntCounter	Local		<input type="checkbox"/>	int32	1									

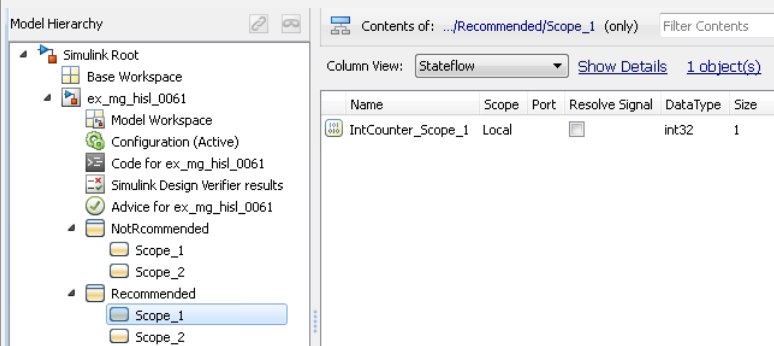
ID: Title	hisl_0061: Unique identifiers for clarity												
	<p>Recommended</p> <p>To clarify the model, create unique identifiers. In the following example, state Scope_1 uses local identifier IntCounter_Scope_1. State Scope_2 uses local identifier IntCounter_Scope_2.</p> <div style="border: 1px dashed black; padding: 10px; margin: 10px 0;"> <p>Scope_1 1</p> <p>% IntCounter_Scope_1 is defined at this scope</p> <p>entry:</p> <pre>IntCounter_Scope_1 = int32(0);</pre> <p>during:</p> <pre>Chart_Level_Output_S1 = Chart_Level_Input + IntCounter_Scope_1; IntCounter_Scope_1 = IntCounter_Scope_1 + int32(1);</pre> </div> <div style="border: 1px dashed black; padding: 10px; margin: 10px 0;"> <p>Scope_2 2</p> <p>% IntCounter_Scope_2 is defined at this scope</p> <p>entry:</p> <pre>IntCounter_Scope_2 = int32(0);</pre> <p>during:</p> <pre>Chart_Level_Output_S2 = Chart_Level_Input + IntCounter_Scope_2; IntCounter_Scope_2 = IntCounter_Scope_2 + int32(1);</pre> </div> <p>The identifier IntCounter_Scope_1 is defined for state Scope_1. Identifier IntCounter_Scope_2 is defined for Scope_2.</p>  <table border="1" data-bbox="682 1267 1142 1328"> <thead> <tr> <th>Name</th> <th>Scope</th> <th>Port</th> <th>Resolve Signal</th> <th>Data Type</th> <th>Size</th> </tr> </thead> <tbody> <tr> <td>IntCounter_Scope_1</td> <td>Local</td> <td></td> <td><input type="checkbox"/></td> <td>int32</td> <td>1</td> </tr> </tbody> </table>	Name	Scope	Port	Resolve Signal	Data Type	Size	IntCounter_Scope_1	Local		<input type="checkbox"/>	int32	1
Name	Scope	Port	Resolve Signal	Data Type	Size								
IntCounter_Scope_1	Local		<input type="checkbox"/>	int32	1								

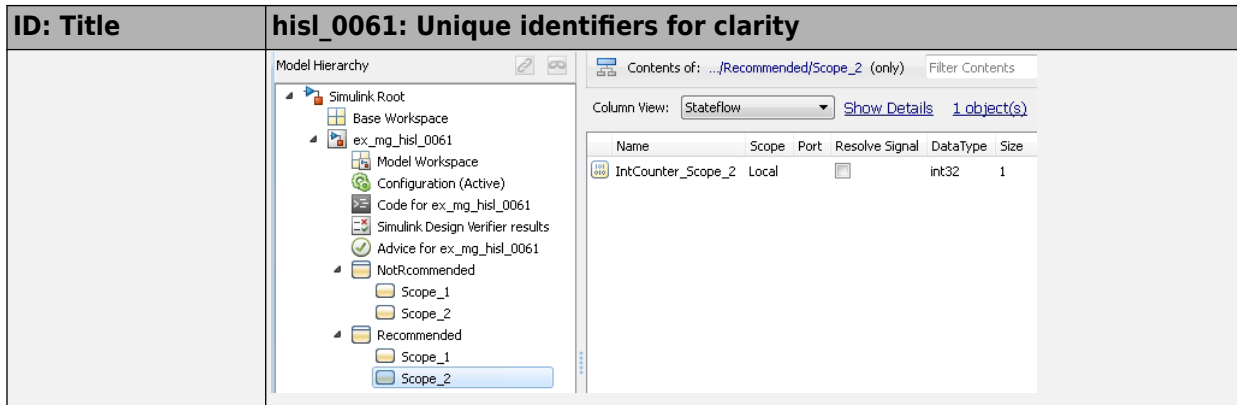

hisl_0062: Global variables in graphical functions

ID: Title	hisl_0062: Global variables in graphical functions
Description	For data with a global scope used in a function, do not use the data in the calling expression if a value is assigned to the data in that function.
Rationale	Enhance readability of a model by removing ambiguity in the values of global variables.
References	<ul style="list-style-type: none"> IEC 61508-3, Table A.3 (3) 'Language subset' IEC 61508-3, Table A.4 (4) 'Modular approach' IEC 61508-3, A.4 (5) 'Design and coding standards' IEC 62304, 5.5.3 - Software Unit acceptance criteria ISO 26262-6, Table 1 (1b) 'Use of language subsets' ISO 26262-6, Table 1 (1f) 'Use of unambiguous graphical representation' ISO 26262-6, Table 1 (1h) 'Use of naming conventions' EN 50128, Table A.4 (11) 'Language Subset' EN 50128, Table A.12 (1) 'Coding Standard' EN 50128, Table A.12 (2) 'Coding Style Guide' DO-331, Section MB.6.3.2.g 'Algorithms are accurate' MISRA C:2012, Rule 13.2 MISRA C:2012, Rule 13.5
Last Changed	R2016a

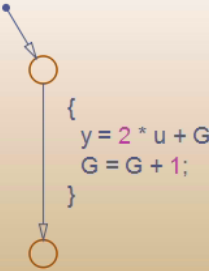
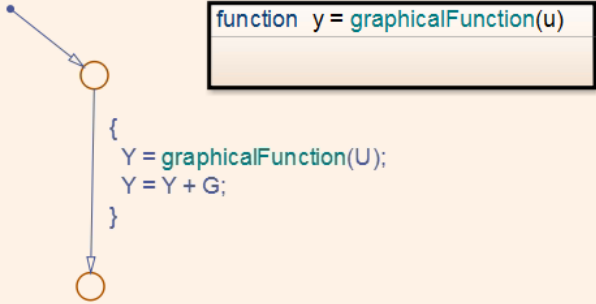
ID: Title	hisl_0062: Global variables in graphical functions
Examples	<p data-bbox="452 302 1310 361">Consider a graphical function <code>graphicalFunction</code> that modifies the global data <code>G</code>.</p> <div data-bbox="476 413 917 765" style="border: 1px solid black; padding: 10px; margin: 10px 0;"> <pre data-bbox="482 420 838 447">function y = graphicalFunction(u)</pre>  </div> <p data-bbox="452 812 649 840">Recommended</p> <div data-bbox="452 873 1084 1229" style="border: 1px solid black; padding: 10px; margin: 10px 0;">  </div> <p data-bbox="452 1263 709 1291">Not Recommended</p>

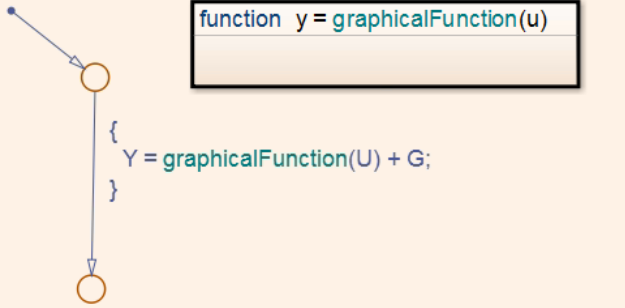
ID: Title	hisl_0062: Global variables in graphical functions
	

hisl_0063: Length of user-defined object names to improve MISRA C:2012 compliance

ID: Title	hisl_0063: Length of user-defined object names to improve MISRA C:2012 compliance
Description	<p>To improve MISRA C:2012 compliance of generated code, limit the length of user defined names to Maximum identifier length (MaxIdLength).</p>
	<p>Note The default of Maximum identifier length is 31.</p>
A	<p>When working with Subsystem blocks with the block parameter Function name options set to User specified, limit the length of function names to parameter Maximum identifier length (MaxIdLength) characters or fewer.</p>

ID: Title	hisl_0063: Length of user-defined object names to improve MISRA C:2012 compliance	
	B	Limit the length of data object names to Maximum identifier length (MaxIdLength) characters or fewer for: <ul style="list-style-type: none"> • Simulink.AliasType • Simulink.NumericType • Simulink.Variant • Simulink.Bus • Simulink.BusElement • Simulink.IntEnumType
	C	Limit the length of signal and parameter names to Maximum identifier length (MaxIdLength) characters or fewer when using the following storage classes: <ul style="list-style-type: none"> • Exported Global • Imported Extern • Imported Extern Pointer • Custom storage class <hr/> Note If specified, this includes the length of the Alias name.
Rationale	User defined names of signal and parameter names to Maximum identifier length (MaxIdLength) characters or fewer when using the following storage classes: <ul style="list-style-type: none"> • Exported Global • Imported Extern • Imported Extern Pointer • Custom storage class <hr/> Note If specified, this includes the length of the Alias name.	

ID: Title	hisl_0063: Length of user-defined object names to improve MISRA C:2012 compliance
References	<ul style="list-style-type: none"> • MISRA C:2012, Rule 5.1 • MISRA C:2012, Rule 5.2 • MISRA C:2012, Rule 5.3 • MISRA C:2012, Rule 5.4 • MISRA C:2012, Rule 5.5
Prerequisites	“hisl_0060: Configuration parameters that improve MISRA C:2012 compliance” on page 7-21
Last Changed	R2017a

hisl_0201: Define reserved keywords to improve MISRA C: 2012 compliance

ID: Title	hisl_0201: Define reserved keywords to improve MISRA C:2012 compliance
Description	To improve MISRA C:2012 compliance of the generated code, define reserved keywords to prevent identifier clashes within the project namespace.
	A In the Configuration Parameters dialog box, on the Simulation Target pane, define reserved identifiers.
	B Use a consistent set of reserved identifiers for all models.
Notes	Simulink Coder™ checks models for standard C language key words. Expand the list of reserved identifiers to include project specific identifiers. Examples include target-specific clashes, standard and custom library clashes, and other identified clashes.
Rationale	Improve MISRA C:2012 compliance of the generated code.
See Also	<ul style="list-style-type: none"> • “Model Configuration Parameters: Simulation Target” in the Simulink documentation • “Reserved Keywords” (Simulink Coder) • “Reserved names” (Simulink Coder)
References	MISRA C:2012, Rule 21.2
Last Changed	R2015b

Block Usage

In this section...

“hisl_0020: Blocks not recommended for MISRA C:2012 compliance” on page 7-13

“hisl_0101: Avoid invariant comparison operations to improve MISRA C:2012 compliance” on page 7-16

“hisl_0102: Data type of loop control variables to improve MISRA C:2012 compliance” on page 7-20

hisl_0020: Blocks not recommended for MISRA C:2012 compliance

ID: Title	hisl_0020: Blocks not recommended for MISRA C:2012 compliance	
Description	To improve MISRA C:2012 compliance of the generated code:	
	A	Use only blocks that support code generation, as documented in the Simulink Block Support Table.
	B	Do not use blocks that are listed as “Not recommended for production code” in the Simulink Block Support Table.
	C	Do not use Lookup Table blocks using cubic spline interpolation or extrapolation methods.
	D	Do not use deprecated Lookup Table blocks. The deprecated Lookup Table blocks are Lookup and Lookup2D.
	E	Do not use S-Function Builder blocks in the model or subsystem.
	F	Do not use From Workspace blocks in the model or subsystem.
Notes	<p>If you follow this and other modeling guidelines, you can eliminate model constructs that are not suitable for C/C++ production code generation, at the same time, increase the likelihood of generating code that complies with the MISRA C:2012 standard.</p> <p>Choose Simulink Help > Simulink > Block Data Types & Code Generation Support > All Tables to view the block support table.</p> <p>Blocks with the footnote (4) in the Block Support Table are classified as “Not Recommended for production code.”</p>	

ID: Title	hisl_0020: Blocks not recommended for MISRA C:2012 compliance	
Rationale	A, B, C, D	Improve quality and MISRA C:2012 compliance of the generated code.
Model Advisor Checks	<p>To check model for conditions A,B,C, D, E, and F:</p> <ul style="list-style-type: none"> • By Task > Modeling Guidelines for MISRA C:2012 > Check for blocks not recommended for MISRA C:2012 • By Task > Modeling Standards for DO-178C/DO-331 > High-Integrity Systems > Code > Check for blocks not recommended for MISRA C:2012 • By Task > Modeling Standards for IEC 61508 > High-Integrity Systems > Code > Check for blocks not recommended for MISRA C: 2012 • By Task > Modeling Standards for IEC 62304 > High-Integrity Systems > Code > Check for blocks not recommended for MISRA C: 2012 • By Task > Modeling Standards for EN 50128 > High-Integrity Systems > Code > Check for blocks not recommended for MISRA C: 2012 • By Task > Modeling Standards for ISO 26262 > High-Integrity Systems > Code > Check for blocks not recommended for MISRA C: 2012 <p>For Modeling Guidelines for MISRA C:2012, see Check for blocks not recommended for MISRA C:2012</p> <p>For DO-178C/DO-331 check details, see Check for blocks not recommended for MISRA C:2012.</p> <p>For IEC 61508, IEC 62304, EN 50128, and ISO 26262 check details, see Check for blocks not recommended for MISRA C:2012.</p>	

ID: Title	hisl_0020: Blocks not recommended for MISRA C:2012 compliance
	<p>To check model for conditions A and B:</p> <ul style="list-style-type: none"> • By Task > Modeling Guidelines for MISRA C:2012 > Check for blocks not recommended for C/C++ production code deployment • By Task > Modeling Standards for DO-178C/DO-331 > High-Integrity Systems > Simulink > Check for blocks not recommended for C/C++ production code deployment • By Task > Modeling Standards for IEC 61508 > High-Integrity Systems > Simulink > Check for blocks not recommended for C/C++ production code deployment • By Task > Modeling Standards for IEC 62304 > High-Integrity Systems > Simulink > Check for blocks not recommended for C/C++ production code deployment • By Task > Modeling Standards for EN 50128 > High-Integrity Systems > Simulink > Check for blocks not recommended for C/C++ production code deployment • By Task > Modeling Standards for ISO 26262 > High-Integrity Systems > Simulink > Check for blocks not recommended for C/C++ production code deployment <p>For Modeling Guidelines for MISRA C:2012, see Check for blocks not recommended for C/C++ production code deployment</p> <p>For DO-178C/DO-331 check details, see Check for blocks not recommended for C/C++ production code deployment.</p> <p>For IEC 61508, IEC 62304, EN 50128, and ISO 26262 check details, see Check for blocks not recommended for C/C++ production code deployment.</p>

ID: Title	hisl_0020: Blocks not recommended for MISRA C:2012 compliance
References	<ul style="list-style-type: none"> • DO-331, Section MB.6.3.2.b 'Low-level requirements are accurate and consistent' • DO-331, Section MB.6.3.2.e 'Low-level requirements conform to standards' • DO-331, Section MB.6.3.4.d 'Source code conforms to standards' • IEC 61508-3, Table A.3 (3) - Language subset • IEC 62304, 5.5.3 - Software Unit acceptance criteria • ISO 26262-6, Table 1 (1b) - Use of language subsets • EN 50128, Table A.4 (11) - Language Subset • MISRA C: 2012
Last Changed	R2017b

hisl_0101: Avoid invariant comparison operations to improve MISRA C:2012 compliance

ID: Title	hisl_0101: Avoid invariant comparison operations to improve MISRA C: 2012 compliance
Description	<p>To improve MISRA C:2012 compliance of generated code, avoid comparison operations with invariant results. Comparison operations are performed by the following blocks:</p> <ul style="list-style-type: none"> • If • Logic • Relational Operator • Switch • Switch Case • Compare to Constant
Note	<p>You can use the design error detection functionality in Simulink Design Verifier to perform the analysis. For more information, see "Dead Logic Detection" (Simulink Design Verifier). If you have a Simulink Design Verifier license, you can use Model Advisor check Detect Dead Logic.</p>
Rationale	<p>Improve MISRA C:2012 compliance of the generated code.</p>

ID: Title	hisl_0101: Avoid invariant comparison operations to improve MISRA C: 2012 compliance
References	<ul style="list-style-type: none">• MISRA C:2012, Rule 14.3• MISRA C:2012, Rule 2.1
Last Changed	R2018a

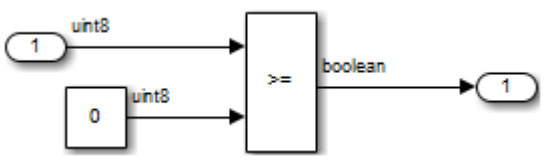
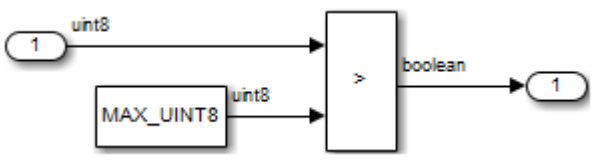
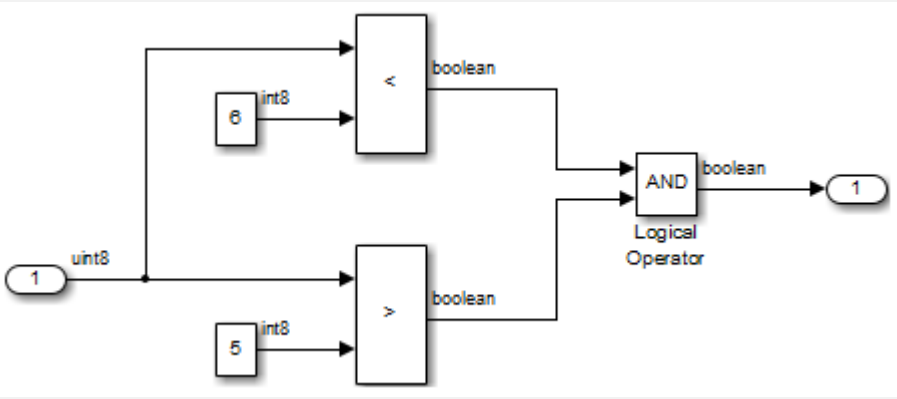
ID: Title	his1_0101: Avoid invariant comparison operations to improve MISRA C: 2012 compliance
Example	<p>Invariant comparisons can occur in simple or compound comparison operations. In compound comparison operations, the individual components can be variable when the full calculation is invariant.</p> <p>Simple: A uint8 is always greater than or equal to 0.</p>  <p>Simple: A uint8 cannot have a value greater than 256</p>  <p>Compound: The comparison operations are mutually exclusive</p>  <p>Stateflow :</p>

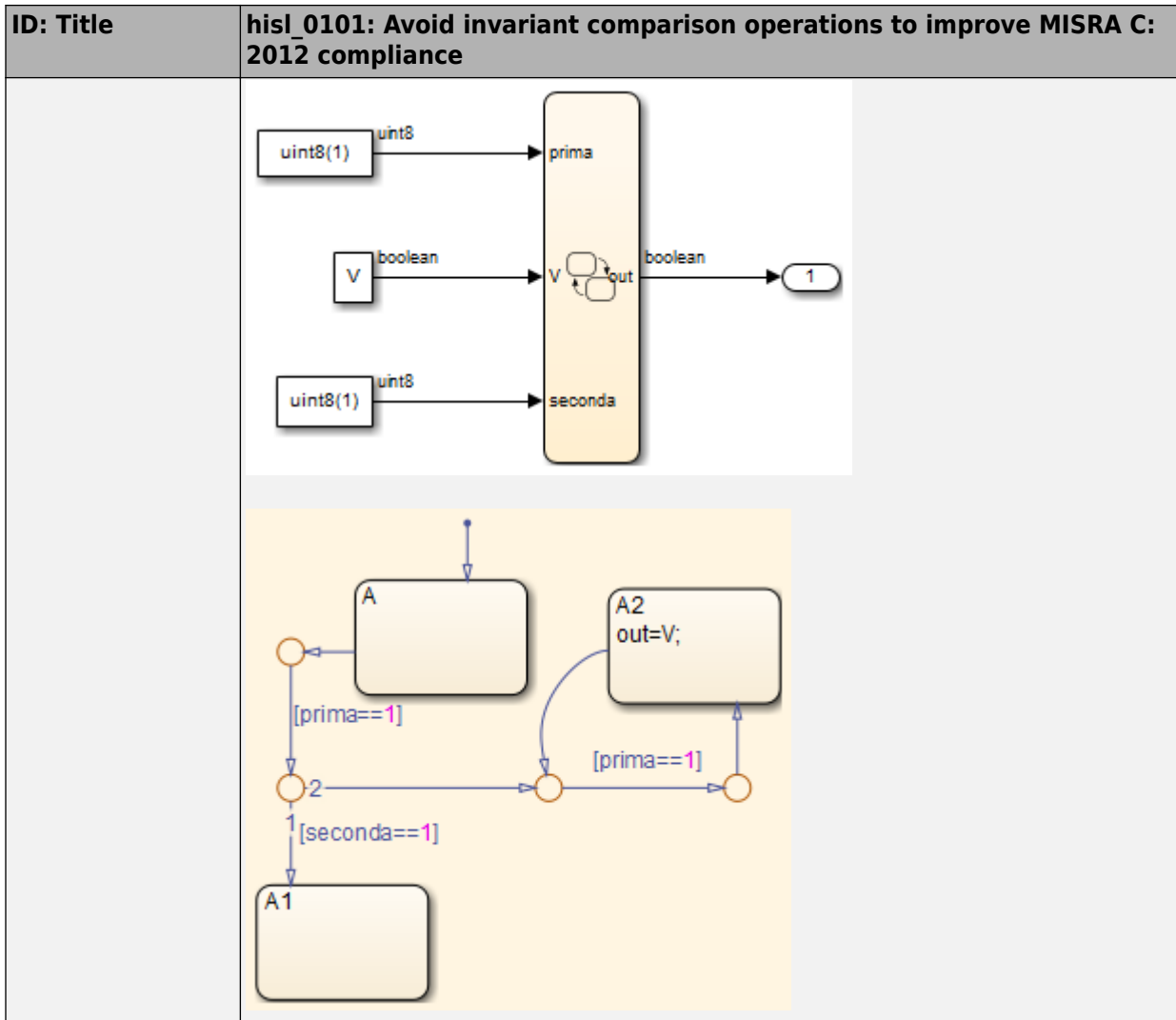

hisl_0102: Data type of loop control variables to improve MISRA C:2012 compliance

ID: Title	hisl_0102: Data type of loop control variables to improve MISRA C:2012 compliance
Description	To improve MISRA C:2012 compliance of generated code, use integer data type for variables that are used as loop control counter variables in: <ul style="list-style-type: none">• For loops constructed in Stateflow and MATLAB.• For Iterator blocks.
Rationale	Improve MISRA C:2012 compliance of the generated code.
References	<ul style="list-style-type: none">• MISRA C:2012, Rule 14.1
Last Changed	R2018a

Configuration Settings

hisl_0060: Configuration parameters that improve MISRA C:2012 compliance

ID: Title	hisl_0060: Configuration parameters that improve MISRA C:2012 compliance
Description	To improve MISRA C:2012 compliance of the generated code,

ID: Title	hisl_0060: Configuration parameters that improve MISRA C:2012 compliance	
	Set the following model configuration parameters as specified:	
	Configuration Parameter	Value
	Math and Data Types:	
	Use division for fixed-point net slope computation	on or Use division for reciprocals of integers only
	Code Generation > Optimization:	
	Bitfield declarator type specifier	uint_T if any of the following configuration parameters are enabled: <ul style="list-style-type: none"> • Pack Boolean data into bitfields • Use bitsets for storing state configuration • Use bitsets for storing Boolean data
	Diagnostics > Data Validity:	
	Model Verification block enabling	Disable all
	Wrap on overflow	warning or error
	Inf or NaN block output	warning or error
	Hardware Implementation:	
	Signed integer division rounds to	Zero or Floor
	Simulation Target:	
	Dynamic memory allocation in MATLAB functions	Cleared (off)
	Code Generation > Target selection:	
System target file	ERT-based target	
Code Generation > Symbols:		

ID: Title	hisl_0060: Configuration parameters that improve MISRA C:2012 compliance	
	Configuration Parameter	Value
	Maximum identifier length	This should be set to the implementation dependent limit. The default is 31.
	System-generated identifiers	Shortened
	Code Generation > Interface:	
	Code replacement library	None or AUTOSAR 4.0
	Shared code placement	Shared location
	Support non-finite numbers	Cleared (off)
	Support: complex numbers	Cleared (off) if you do not need complex number support
	Support continuous time	Cleared (off)
	Mat-file logging	Cleared (off)
	Generate shared constants	Cleared (off)
	Standard math library	C89/C90 (ANSI) or C99 (ISO) depending on toolchain
	Support non-inlined S-functions	Cleared (off)
	Use dynamic memory allocation for model initialization	Cleared (off) Select only when configuration parameter Code Interface Packaging is set to Reusable Function.
	Code Generation > Code Style > Code Style:	
	Parentheses level	Maximum (Specify precedence with parentheses)
	Replace multiplications by powers of two with signed bitwise shifts	Cleared (off)
	Casting modes	Standards Compliant

ID: Title	hisl_0060: Configuration parameters that improve MISRA C:2012 compliance	
	Configuration Parameter	Value
	Allow right shifts on signed integers	Cleared (off)
	Preserve static keyword in function declarations	Selected (on) Select only when configuration parameter File packaging format is set to Compact or CompactWithDataFile
Rationale	Improve MISRA C:2012 compliance of the generated code.	

ID: Title	hisl_0060: Configuration parameters that improve MISRA C:2012 compliance
Model Advisor Checks	<ul style="list-style-type: none"> • By Task > Modeling Guidelines for MISRA C:2012 > Check configuration parameters for MISRA C:2012 • By Task > Modeling Standards for DO-178C/DO-331 > High-Integrity Systems > Code > Check configuration parameters for MISRA C:2012 • By Task > Modeling Standards for IEC 61508 > High-Integrity Systems > Code > Check configuration parameters for MISRA C: 2012 • By Task > Modeling Standards for IEC 62304 > High-Integrity Systems > Code > Check configuration parameters for MISRA C: 2012 • By Task > Modeling Standards for EN 50128 > High-Integrity Systems > Code > Check configuration parameters for MISRA C: 2012 • By Task > Modeling Standards for ISO 26262 > High-Integrity Systems > Code > Check configuration parameters for MISRA C: 2012 <p>For Modeling Guidelines for MISRA C:2012, see Check configuration parameters for MISRA C:2012</p> <p>For DO-178C/DO-331 check details, see Check configuration parameters for MISRA C:2012.</p> <p>For IEC 61508, IEC 62304, EN 50128, and ISO 26262 check details, see Check configuration parameters for MISRA C:2012.</p>
References	<ul style="list-style-type: none"> • MISRA C:2012
Last Changed	R2018a

Stateflow Chart Considerations

In this section...

“hisf_0064: Shift operations for Stateflow data to improve code compliance” on page 7-26

“hisf_0065: Type cast operations in Stateflow to improve code compliance” on page 7-28

“hisf_0211: Protect against use of unary operators in Stateflow Charts to improve code compliance” on page 7-29

“hisf_0213: Protect against divide-by-zero calculations in Stateflow charts to improve MISRA C:2012 compliance” on page 7-31

hisf_0064: Shift operations for Stateflow data to improve code compliance

ID: Title	hisf_0064: Shift operations for Stateflow data to improve code compliance	
Description	To improve code compliance of the generated code with Stateflow bit-shifting operations, do not perform:	
	A	Right-shift operations greater than the bit-width of the input type, or by a negative value.
	B	Left-shift operations greater than the bit-width of the output type, or by a negative value.
Note	If you follow this and other modeling guidelines, you increase the likelihood of generating code that complies with the coding standards.	
Rationale	A,B	To avoid shift operations in the generated code that might be a coding standard violation.

ID: Title	hisf_0064: Shift operations for Stateflow data to improve code compliance
Model Advisor Checks	<ul style="list-style-type: none"> • By Task > Modeling Standards for DO-178C/DO-331 > Check usage of shift operations for Stateflow data • By Task > Modeling Standards for IEC 61508 > Check usage of shift operations for Stateflow data • By Task > Modeling Standards for IEC 62304 > Check usage of shift operations for Stateflow data • By Task > Modeling Standards for EN 50128 > Check usage of shift operations for Stateflow data • By Task > Modeling Standards for ISO 26262 > Check usage of shift operations for Stateflow data <p>For DO-178C/DO-331 check details, see Check usage of shift operations for Stateflow data.</p> <p>For IEC 61508, IEC 62304, EN 50128, and ISO 26262 check details, see Check usage of shift operations for Stateflow data.</p>
References	<ul style="list-style-type: none"> • DO-331 Section MB.6.3.1.b 'High-level requirements are accurate and consistent' • DO-331 Section MB.6.3.2.b 'Low-level requirements are accurate and consistent' • IEC 61508-3, Table A.3 (2) Strongly typed programming language • IEC 61508-3, Table A.4 (3) Defensive programming • IEC 62304, 5.5.3 - Software Unit acceptance criteria • ISO 26262-6, Table 1 (1b) Use of language subsets • ISO 26262-6, Table 1 (1c) Enforcement of strong typing • ISO 26262-6, Table 1 (1d) Use of defensive implementation techniques • EN 50128, Table A.4 (8) Strongly Typed Programming Language • EN 50128, Table A.3 (1) Defensive Programming
Prerequisites	"hisl_0060: Configuration parameters that improve MISRA C:2012 compliance" on page 7-21
Last Changed	R2017b

hisf_0065: Type cast operations in Stateflow to improve code compliance

ID: Title	hisf_0065: Type cast operations in Stateflow to improve code compliance	
Description	To improve code compliance of the generated code, protect against Stateflow casting integer and fixed-point calculations to wider data types than the input data types by:	
	A	Using the := notation in Stateflow charts that use the C action language
Note	If you follow this and other modeling guidelines, you increase the likelihood of generating code that complies with the coding standards.	
Rationale	A	To avoid implicit casts in the generated code that might be a coding standards violation.
Model Advisor Checks	<ul style="list-style-type: none"> • By Task > Modeling Standards for DO-178C/DO-331 > Check type cast operations in Stateflow • By Task > Modeling Standards for IEC 61508 > Check type cast operations in Stateflow • By Task > Modeling Standards for IEC 62304 > Check type cast operations in Stateflow • By Task > Modeling Standards for EN 50128 > Check type cast operations in Stateflow • By Task > Modeling Standards for ISO 26262 > Check type cast operations in Stateflow <p>For DO-178C/DO-331 check details, see Check assignment operations in Stateflow charts.</p> <p>For IEC 61508, IEC 62304, EN 50128, and ISO 26262 check details, see Check assignment operations in Stateflow charts.</p>	

ID: Title	hisf_0065: Type cast operations in Stateflow to improve code compliance
References	<ul style="list-style-type: none"> • DO-331 Section MB.6.3.1.b 'High-level requirements are accurate and consistent' • DO-331 Section MB.6.3.2.b 'Low-level requirements are accurate and consistent' • IEC 61508-3, Table A.3 (2) Strongly typed programming language • IEC 61508-3, Table A.4 (3) Defensive programming • IEC 62304, 5.5.3 - Software Unit acceptance criteria • ISO 26262-6, Table 1 (1b) Use of language subsets • ISO 26262-6, Table 1 (1c) Enforcement of strong typing • ISO 26262-6, Table 1 (1d) Use of defensive implementation techniques • EN 50128, Table A.4 (8) Strongly Typed Programming Language • EN 50128, Table A.3 (1) Defensive Programming
Prerequisites	"hisf_0060: Configuration parameters that improve MISRA C:2012 compliance" on page 7-21
Last Changed	R2017b

hisf_0211: Protect against use of unary operators in Stateflow Charts to improve code compliance

ID: Title	hisf_0211: Protect against use of unary operators in Stateflow Charts to improve code compliance	
Description	To improve code compliance of the generated code:	
	A	Do not use unary minus operators on unsigned data types
Note	The MATLAB and C action languages do not restrict the use of unary minus operators on unsigned expressions.	
Rationale	A	Improve code compliance of the generated code.

ID: Title	hisf_0211: Protect against use of unary operators in Stateflow Charts to improve code compliance
Model Advisor Checks	<ul style="list-style-type: none"> • By Task > Modeling Standards for DO-178C/DO-331 > Check type cast operations in Stateflow • By Task > Modeling Standards for IEC 61508 > Check type cast operations in Stateflow • By Task > Modeling Standards for IEC 62304 > Check type cast operations in Stateflow • By Task > Modeling Standards for EN 50128 > Check type cast operations in Stateflow • By Task > Modeling Standards for ISO 26262 > Check type cast operations in Stateflow <p>For DO-178C/DO-331 check details, see Check Stateflow charts for unary operators.</p> <p>For IEC 61508, IEC 62304, EN 50128, and ISO 26262 check details, see Check Stateflow charts for unary operators.</p>
References	<ul style="list-style-type: none"> • DO-331 Section MB.6.3.1.b 'High-level requirements are accurate and consistent' • DO-331 Section MB.6.3.2.b 'Low-level requirements are accurate and consistent' • IEC 61508-3, Table A.3 (2) Strongly typed programming language • IEC 61508-3, Table A.4 (3) Defensive programming • IEC 62304, 5.5.3 - Software Unit acceptance criteria • ISO 26262-6, Table 1 (1b) Use of language subsets • ISO 26262-6, Table 1 (1c) Enforcement of strong typing • ISO 26262-6, Table 1 (1d) Use of defensive implementation techniques • EN 50128, Table A.4 (8) Strongly Typed Programming Language • EN 50128, Table A.3 (1) Defensive Programming • MISRA C:2012, Rule 10.1
Last Changed	R2017b

hisf_0213: Protect against divide-by-zero calculations in Stateflow charts to improve MISRA C:2012 compliance

ID: Title	hisf_0213: Protect against divide-by-zero calculations in Stateflow charts to improve MISRA C:2012 compliance	
Description	To improve MISRA C:2012 compliance of the generated code for floating point and integer-based operations, do one of the following:	
	A	Perform static analysis of the model to prove that division by zero is not possible
	B	Provide run-time error checking in the generated C code by explicitly modeling the error checking in Stateflow
	C	Modify the code generation process using Code Replacement Libraries (CRLs) to protect against division by zero
	D	For integer-based operations, clear configuration parameter Remove code that protects against division arithmetic exceptions
Note	<p>Using run-time error checking introduces additional computational and memory overhead in the generated code. Therefore, it is preferable to use static analysis tools to limit errors in the generated code.</p> <p>You can use the design error detection functionality in Simulink Design Verifier to perform the static analysis. For more information, see “Static Run-Time Error Detection” (Simulink Design Verifier). Alternatively, if you have a Simulink Design Verifier license, you can use Model Advisor check Detect Division by Zero to identify division-by-zero errors in your model.</p> <p>If static analysis determines that sections of the code can have a division by zero, then add run-time protection into that section of the model (see example). Using a modified CRL or selecting the parameter Remove code that protects against division arithmetic exceptions protects division operations against divide-by-zero operations. However, this action does introduce additional computational and memory overhead.</p> <p>Use only one of the run-time protections (B, C or D) in a model. Using more than one option can result in redundant protection operations.</p>	
Rationale	A,B, C,D	Improve MISRA C:2012 compliance of the generated code

ID: Title	hisf_0213: Protect against divide-by-zero calculations in Stateflow charts to improve MISRA C:2012 compliance
References	<ul style="list-style-type: none"> • MISRA C:2012, Dir 4.1
See Also	<ul style="list-style-type: none"> • “What Is Code Replacement?” (Simulink Coder) and “Code Replacement Libraries” (Simulink Coder) • “hisl_0002: Usage of Math Function blocks (rem and reciprocal)” on page 2-4 • “hisl_0005: Usage of Product blocks” on page 2-13 • “hisl_0054: Configuration Parameters > Code Generation > Optimization > Remove code that protects against division arithmetic exceptions” on page 5-48 • Detect Division by Zero
Last Changed	R2018a

ID: Title	hisf_0213: Protect against divide-by-zero calculations in Stateflow charts to improve MISRA C:2012 compliance
Example	<p>Run-time divide by zero protection can be realized using a graphical function. Unique functions should be provided for each data type.</p> <div style="background-color: #fff9c4; padding: 10px; margin-bottom: 10px;"> <p style="text-align: right; margin-right: 20px;"><i>Graphical function to model divide-by-zero check</i></p> <pre>{d_int_pro = div_fun_int(b_int, c_int);... d_dbl_pro = div_fun_dbl(b_dbl, c_dbl, 10000.0, 0.001);}</pre> </div> <div style="display: flex; justify-content: space-around;"> <div style="border: 1px solid black; padding: 5px; width: 45%;"> <p>function result = div_fun_dbl(num, den, maxVal, eps)</p> </div> <div style="border: 1px solid black; padding: 5px; width: 45%;"> <p>function result = div_fun_int(num, den)</p> </div> </div> <div style="background-color: #fff9c4; padding: 10px; margin-top: 10px;"> <p style="text-align: right; margin-right: 20px;"><i>Graphical function to model divide-by-zero check</i></p> <pre>{d = div_fun(b,c);}</pre> <div style="border: 1px solid black; padding: 5px; margin-top: 10px;"> <p>function result = div_fun(num, den)</p> </div> </div>

Requirements Considerations

Requirement Considerations

hisl_0070: Placement of requirement links in a model

ID: Title	hisl_0070: Placement of requirement links in a model	
Description	Establish bidirectional traceability between model requirements and the model elements that are used to implement the requirement. A single element or combination of elements can link to requirements.	
	When linking requirements, follow these guidelines.	
	A	Apply requirement links to the lowest level component of model elements. Model elements that do not impact the model's behavior or the generated code are exempt from requirement linking. See Notes for additional information.
	B	At the project level, define the maximum number of unique requirement links associated with each component. A minimum of one requirement link is required.
C	At the project level, define the maximum number of child model elements for each linked component.	

ID: Title	hisl_0070: Placement of requirement links in a model	
Notes	<p>Use Simulink Requirements™ to trace between the model and the requirements from which the model was developed. Apply user tags (Simulink Requirements) to define model elements as derived and/or safety requirements.</p> <p>To reduce the number of requirements that are linked to a model, apply requirements at the component-level. A component contains a group of model elements, for example:</p> <ul style="list-style-type: none"> • In Simulink, a component is a top-level block diagram, subsystem, MATLAB function, or area annotation. • In Stateflow, a component is a chart, superstate, box, Simulink function, or graphical function. <p>Components that contain <i>only</i> these model elements are exempt from requirement linking:</p> <ul style="list-style-type: none"> • Model Info, DocBlock, or System Requirements blocks • Area annotations • Model element with requirement links <p>When a linked component contains a nonexempt child model element, the child implements the associated requirement either in part or whole.</p>	
Rationale	A	Establishing requirement links at the component level captures the relationship of model elements. In addition, maintainability improves because the need to update requirement links for minor logic changes is reduced.
	B, C	Support requirement change impact analysis.

ID: Title	hisl_0070: Placement of requirement links in a model
References	<ul style="list-style-type: none"> • DO-331, Section MB.6.3.1.f - High-level requirements trace to system requirements • DO-331, Section MB.6.3.2.f - Low-level requirements trace to high-level requirements • IEC 61508-3, Table A.2 (12) - Computer-aided specification and design tools, Table A.2 (9) - Forward traceability between the software safety requirements specification and software architecture, Table A.2 (10) - Backward traceability between the software safety requirements specification and software architecture, Table A.4 (8) - Forward traceability between the software safety requirements specification and software design, Table A.8 (1) - Impact analysis • IEC 62304, 5.2 - Software requirements analysis, 7.4.2 - Analyze impact of software changes on existing risk control measures • ISO 26262-6, Table 8 (1a) - Documentation of the software unit design in natural language, ISO 26262-6: 7.4.2.a - The verifiability of the software architectural design, ISO 26262-8: 8.4.3 Change request analysis • EN 50128, Table A.3 (23) - Modeling supported by computer aided design and specification tools, Table D.58 - Traceability, Table A.10 (1) - Impact Analysis

ID: Title	hisl_0070: Placement of requirement links in a model
Model Advisor Check	<ul style="list-style-type: none"> • By Task > Modeling Standards for DO-178C/DO-331 > High-Integrity Systems > Requirements > Check for model elements that do not link to requirements • By Task > Modeling Standards for IEC 61508 > High-Integrity Systems > Requirements > Check for model elements that do not link to requirements • By Task > Modeling Standards for IEC 62304 > High-Integrity Systems > Requirements > Check for model elements that do not link to requirements • By Task > Modeling Standards for ISO 26262 > High-Integrity Systems > Requirements > Check for model elements that do not link to requirements • By Task > Modeling Standards for EN 50128 > High-Integrity Systems > Requirements > Check for model elements that do not link to requirements <p>For DO-178C/DO-331 check details, see Check for model elements that do not link to requirements.</p> <p>For IEC 61508, IEC 62304, EN 50128, and ISO 26262 check details, see Check for model elements that do not link to requirements.</p>
See Also	<ul style="list-style-type: none"> • “Requirements Traceability in Simulink” • “Requirements Traceability and Consistency” (Simulink Requirements)
Last Changed	R2017b

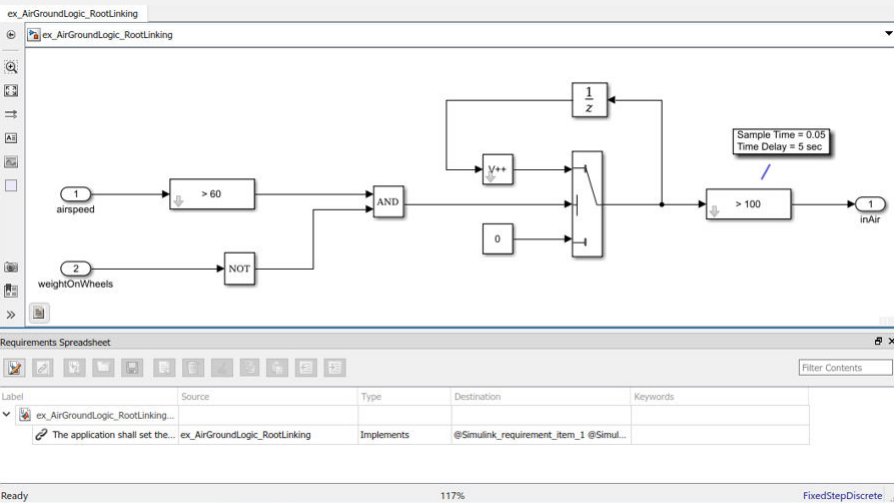
<p>ID: Title</p>	<p>hisl_0070: Placement of requirement links in a model</p>
<p>Examples</p>	<p>Recommended: Requirement links on parent component</p> <p>Requirement link placed at the top level model with no subsystems.</p> 
	<p>Recommended: Requirement links placed on area annotation</p> <p>Requirement link placed on an area annotation.</p> 